



INSTALLATION GUIDE

NOVANO 6" & 4" SIDING QUIK-TRIM SYSTEM

I. INTRODUCTION

SECTION 1

Material Components

SECTION 2

Basics

SECTION 3

Scope of Delivery

II. INSTALLATION PROCEDURE

SECTION 1

Batten Substructure

SECTION 2

Trim and Accessory Options

SECTION 3

Horizontal Siding Application

SECTION 4

Multi-board Horizontal Siding
Application

SECTION 5

Vertical Siding Application

SECTION 6

Multi-board Vertical Siding
Application

SECTION 7

Air Barrier Requirements

SECTION 8

Finishing Option -
Trims and Hollow Cap

SECTION 9

Prime and Stain System

III. SAFETY WARNING



I. INTRODUCTION

Engineered for architectural consistency and lifetime durability, the NOVANO Siding utilizes a high-performance board profile. Finished by Quik-Trim System, it ensures a seamless, screw-free finish across every application.

NOVANO composite siding is a **fully integrated system** designed to deliver consistent performance, visual continuity, and reliable installation results across residential and commercial projects. Every component, from the Siding Board to the Quik-Trims and fastening elements, works together as one coordinated solution.

This approach simplifies specification, reduces installation complexity, and ensures a clean, cohesive finish from deck surface to perimeter details.

SECTION 1 - MATERIAL COMPONENTS

The traditional construction industry has long been limited by the biological vulnerabilities of timber. At NOVANO, we have moved beyond mere imitation to True Engineering. Our technology is centered on a proprietary synthesis of natural innovation and high-performance polymers, creating a wood-free composite that excels where organic fibers fail.

By manipulating the molecular structure of our raw materials, we ensure high-density fiber reinforcement that provides unrivaled dimensional stability and moisture resistance. This is Nature Reinvented, a next-generation material designed to meet the rigorous mechanical demands of global architectural standards while offering a superior total value through long-term structural integrity.

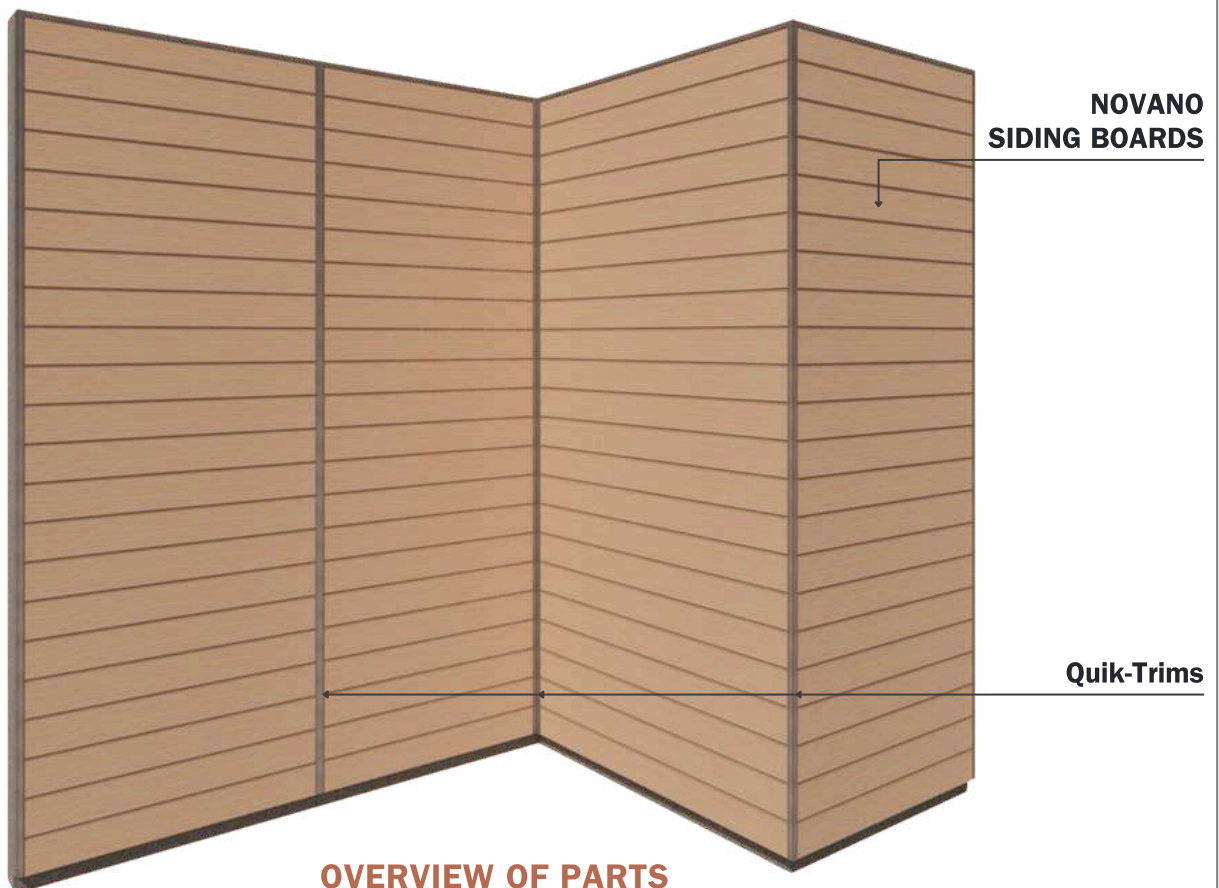

SECTION 2 - BASICS

HTC3410
Siding Hat Channel

NV-SIDAC-25-SS
Shoulder SS Screw

NOVANO
Siding Profile



QTJM10
Quik-Trim
J-Mold

QTOC10
Quik-Trim
Outside Corner

QTWJM10
Quik-Trim
Windows J-Mold

QTHM10
Quik-Trim
H-Mold



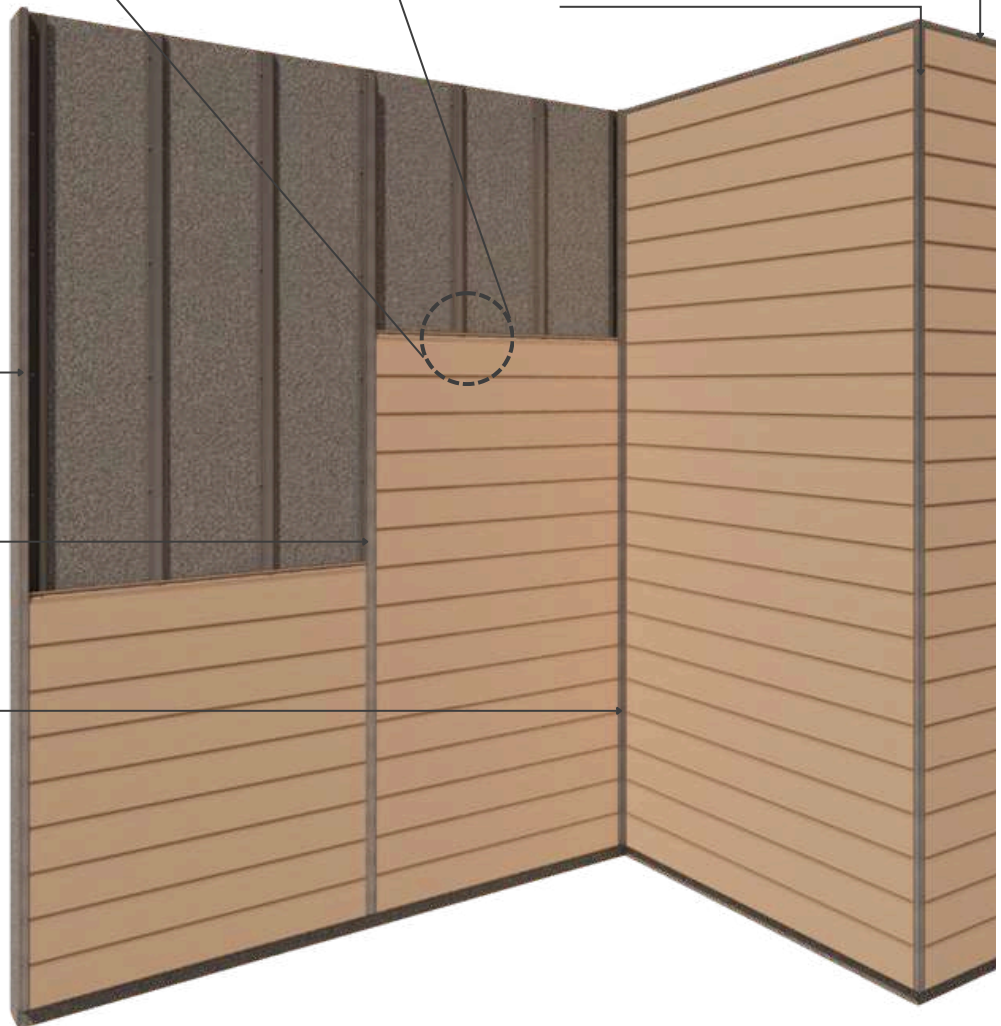











QTIC10
Quik-Trim
Inside Corner



ISOMETRIC VIEW
Basic Parts of Siding Board (Siding 6" & 4")
Quik-Trim System



SECTION 3 - SCOPE OF DELIVERY

ITEM No.	PRODUCT NAME & SPECIFICATION	ISOMETRIC VIEW	SECTION VIEW
1	NV-SID-9513-H ½" x 4" x 12' Hollow Siding Profile		
2	NV-SID-14013-H ½" X 6" X 12' Hollow Siding Profile		
3	HTC3410 ¾" X 1 ½" Siding Hat Channel Mill Finish		
4	HTC3410P ¾" X 1 ½" Siding Hat Channel Punched Mill Finish		
5	QTWJM10 1" x 1-37/64" Quik-Trim Windows J-Mold with Quik-Trim PVC Base		
6	QTOC10 1" x 1" Quik-Trim Outside Corner with Outside Corner Quik-Trim PVC Base		
7	QTIC10 1-37/64" x 1-37/64" Quik-Trim Inside Corner with Quik-Trim PVC Base		

SECTION 3 - SCOPE OF DELIVERY







ITEM No.	PRODUCT NAME & SPECIFICATION	ISOMETRIC VIEW	SECTION VIEW
8	QTHM10 1-37/64" Quik-Trim H-Mold with Quik-Trim PVC Base		
9	QTJM10 1" x 25/32" Quik-Trim J-Mold with Quik-Trim PVC Base		
10	SVJS10 Siding Starter J-Strip		
11	NV-SIDAC-25-SS 1" TEC Shoulder Stainless Steel Screw		

Table 1.1 - Scope of Delivery

NOTE:

To view a complete list of products, please refer to our NOVANO brochure or visit our website www.novanobuildingproducts.com

IMPORTANT: Five Major Bullet Points You Must Follow for a Successful NOVANO Siding Installation

- Screw Placement
- Room for Expansion and Contraction
- Hard Fastening of each Plank
- Top to Bottom Ventilation
- Span over 16'' between supports, 3 hat channels are required

Note:

Proper planning of the Siding Board layout is essential for ease of installation of Siding Boards and siding components.

Thoroughly read the following siding assembly instructions and obtain all necessary building permits prior to starting your installation.

Decide finishing and trimming options prior to starting the project to ensure the siding finishing detail is uniform for all sides of the building

Installation is the sole responsibility of the installer. **NOVANO Company assumes no responsibility whatsoever with respect to the installation.** The information contained herein is provided for guidance purposes only and should not be relied upon as any absolute representation by NOVANO.



Packed finished material must be kept dry.

When packed, finished NOVANO Products are exposed to moisture, and it can develop mold/mildew on the board surfaces if left packed/bundled.

If packed material is exposed to moisture, open it immediately and spread the material to allow surfaces to dry.

This condition only applies to packed material. Finished NOVANO Products installed in exterior applications will not exhibit this issue.

SAFETY TIPS

1. Always check for power, gas, and water lines before installing.
2. Always wear safety glasses when operating power equipment.

ASSEMBLY TIPS

1. Battens should be flat and level with each other. Siding will follow the contour of the wall.
2. NOVANO Siding System is not a rainscreen or waterproof system. NOVANO Siding Board is a watershed system.
3. Proper wall preparation according to local building codes and wall covering manufacturer's recommendations should be adhered to. This includes but is not limited to flashing all openings.
4. All holes should be predrilled and installation holes should be slotted.
5. Only use construction fastening material and hardware suitable for outdoor use (e.g. stainless steel screws). Recommended is the use of NV-SIDAC-25-SS shoulder screw.
6. Always consider the linear expansion of NOVANO, which is dependent on the temperature but not the air humidity. See *Table 1.3 "NOVANO Expansion"* for more information.
7. Cut-off pieces and/or abrasive dust must be disposed of separately. Please comply with the regulations of your local waste management provider. You may under no circumstances burn NOVANO.
8. Cutting to length should be carried out at consistent material temperature. Therefore, the material should be stored in the shade or in areas where it is not exposed to direct sunlight. The material can warm up considerably in the sun, leading to an increased change in length. In the case of more distinct fluctuations in material temperature, cutting to length may have to be adapted accordingly.
9. Please store NOVANO Products flat on a level surface.



MANDATORY VENTILATION

Cross ventilation (also called *Wind Effect Ventilation*) is a natural method of cooling. The system relies on wind to force cool exterior air into the building through an inlet (like a wall louver, a gable, or an open window) while outlet forces warm interior air outside (through a roof vent or higher window opening).

In NOVANO Siding Installation, the 3" Gap at the bottom part of Siding System acts as the cool exterior air INLET while the 1/2" Gap on top acts as the warm interior air OUTLET. The air gap between wall surface and Siding Boards resultant from the battens sub frames height allows passage air flow for cross ventilation through the SIDING QUIK TRIM INSTALLATION SYSTEM.

ADJACENT SURFACE

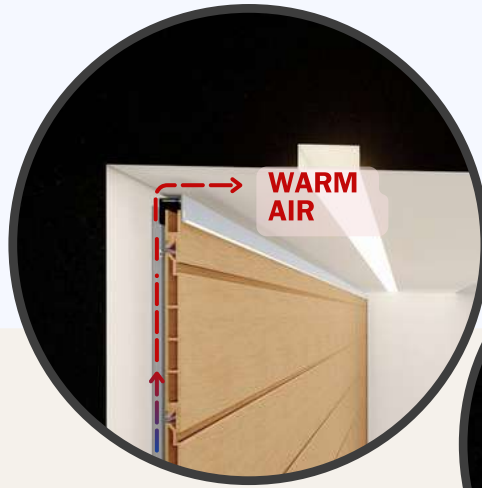
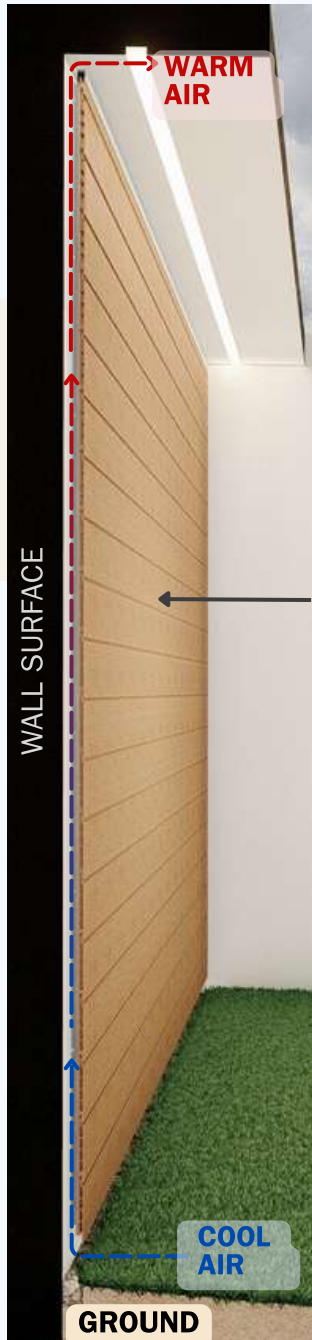

SIDING QUIK-TRIM SYSTEM INSTALLATION

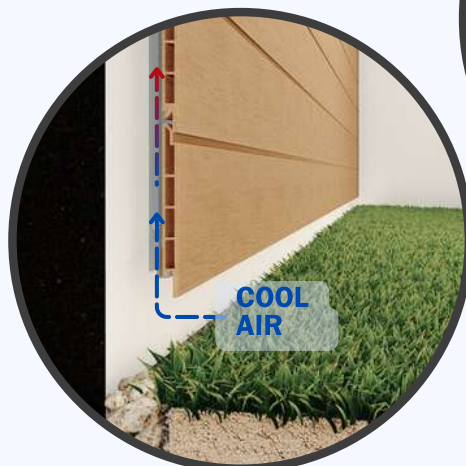
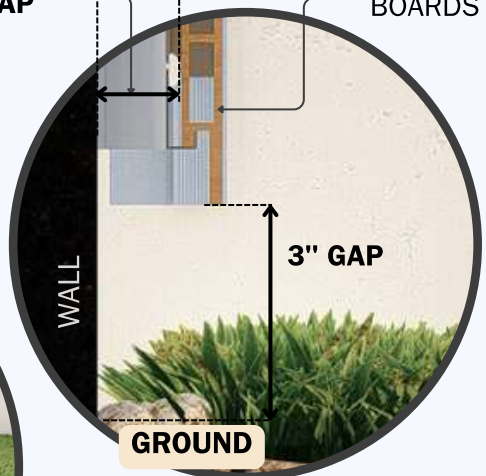
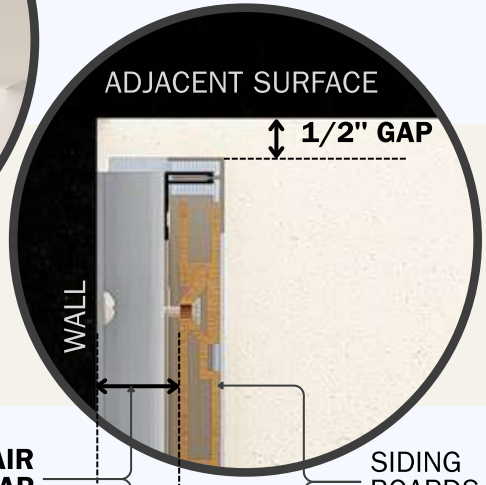

CROSS VENTILATION
Siding 6" & 4"
Quik-Trim System

CODE COMPLIANT BATTEN SPACING

Part Number	Part Description	Joist Span (in)
NV-SID-14013-H	Siding Board Flat 1/2" x 6" (0.530" x 6")	16"
NV-SID-9513-H	Siding Board Flat 1/2" x 4" (0.530" x 4")	16"

Table 1.2 Batten Spacing Requirements

Recommendation for Batten Spacing

If the siding is being installed in a hot southern location and will be exposed to direct sunlight for the majority of each day and/or the siding will be stained a dark color, the batten spacing is suggested be reduced to 8" or 12" center-to-center for all siding profiles.

EXPANSION / CONTRACTION OF SIDING

NOVANO Expansion - Contraction Guide	
Profile Length	12 ft
Expansion / Contraction amount (approximately 0.3% over 90 °F variation in temperature)	$\frac{7}{16}$ " (0.432")

Table 1.3 - NOVANO Expansion

**Average expected expansion-contraction
(this can vary based on the geographical region)**

Ensure a steady material temperature when cutting the boards to size, i.e. the cutting has to be done under constant conditions, e.g. inside or in shade

Always consider the linear expansion of NOVANO profiles during the installation of siding products. If temperatures fluctuate during the installation, the gaps placed between the ends of the boards and a corner, window, or door must change with the temperature. Use the guide above to gap boards during installation..

NOVANO Siding Board Gap Guide					
Temperature at Installation	End to End Siding Boards				Wall Gap
	Below 30°F	60°F	90°F	120°F	
Amount for Siding Profile Length of 12 ft	$\frac{7}{16}$ "	$\frac{1}{4}$ "	$\frac{1}{16}$ "	0"	$\frac{1}{4}$ "

Table 1.4 - NOVANO Gap Guide



Expansion - Contraction Tips

1. Control Piece

At the start of the day, cut a length of board that is desired to be installed and keep this board in the same area as the cutting and storage of the remaining boards. This board will be a “Control Piece” to reference when cutting other boards to be installed. Throughout the day, the “Control Piece” can be referenced and the saw cuts adjusted accordingly as the boards expand and/or contract. The heat from the sun will cause NOVANO boards to expand, so if the material is stored in the shade, keep the “Control Piece” in the shade as well.

Example:

If 12 ft boards are being installed cut one 12 ft board at the start of the day. Reference these boards throughout the day and adjust the cutting of the other boards to match.

2. Control Gap

At the start of the installation, place the board gap according to *Table 1.4* and mark the first gap made. This gap will be a “Control Gap” to reference when gapping the remaining boards to be installed.

Throughout the installation, refer back to this “Control Gap” to match the other gaps being installed. This will ensure that all the gaps installed are the same.

II. INSTALLATION PROCEDURE

SECTION 1 - SUBSTRUCTURE

General Notes on Batten Substructure

NOVANO Siding Boards can be installed in horizontal or vertical applications and the batten substructure should be planned to accommodate how the Siding Boards will be installed.

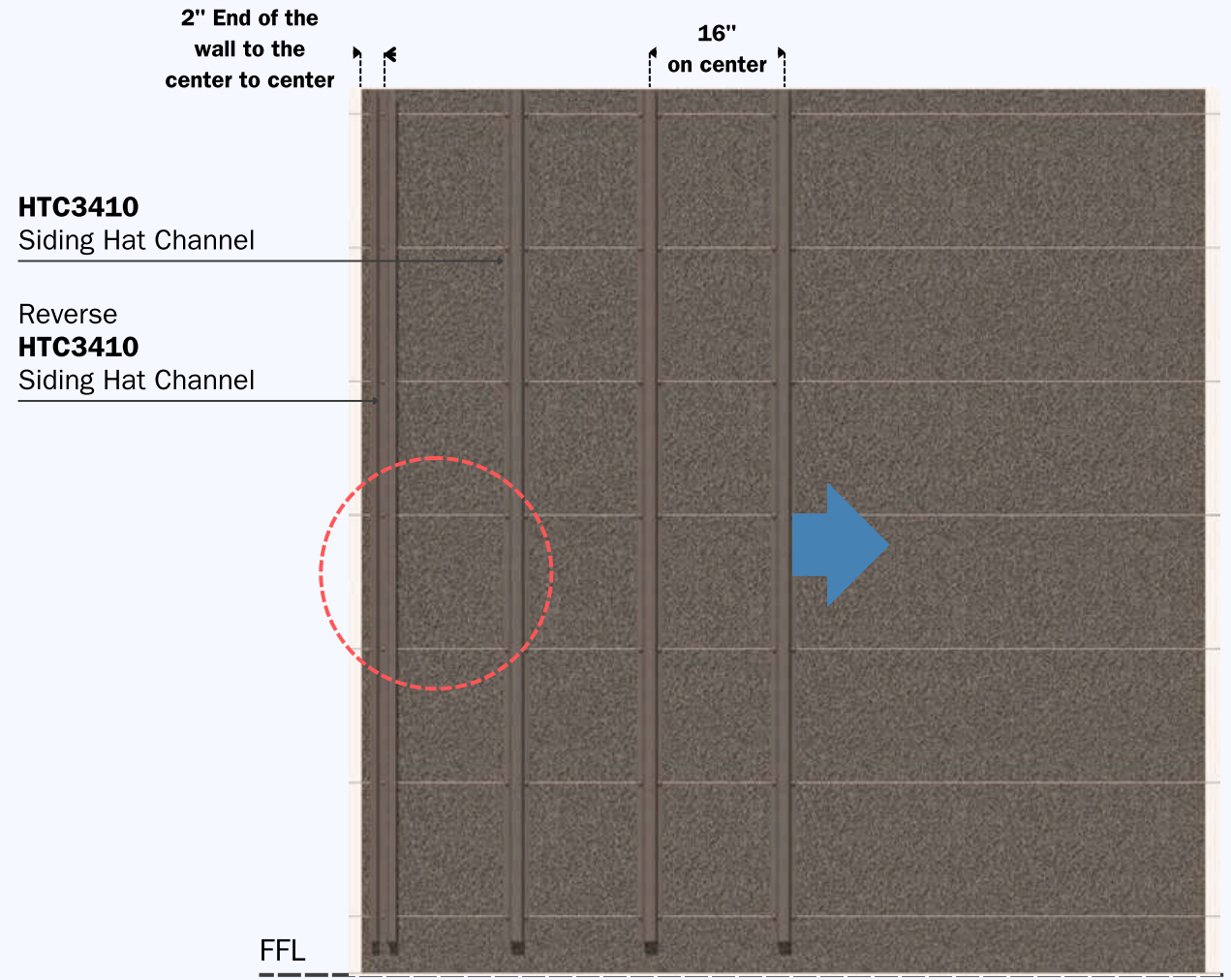

FRONT ELEVATION
Substructure
Siding 6" & 4"
Quik-Trim System

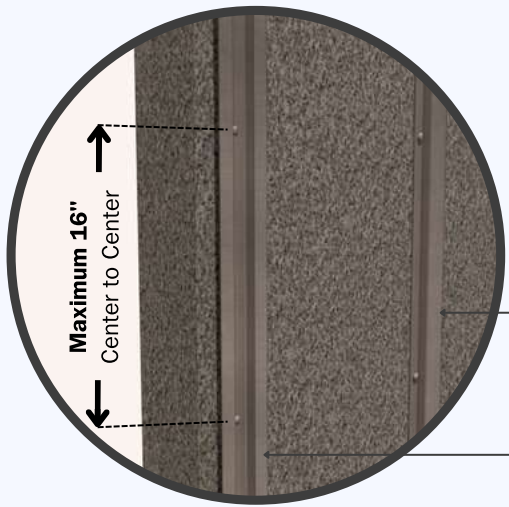

HTC3410
Siding Hat Channel

Reverse
HTC3410
Siding Hat Channel

DETAIL
Substructure



HTC3410
Siding Hat Channel

Reverse
HTC3410
Siding Hat Channel



FRONT ELEVATION
Substructure
Siding 6" & 4"
Quik-Trim System

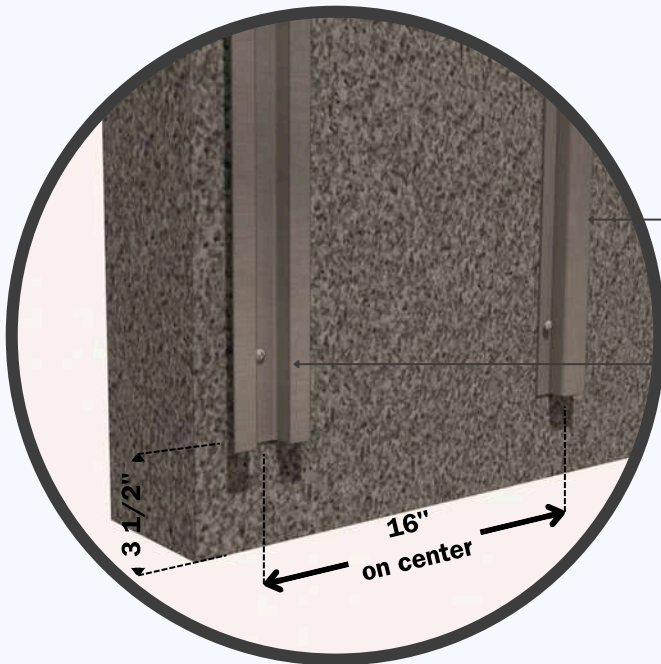

HTC3410
Siding Hat Channel

Reverse
HTC3410
Siding Hat Channel

DETAIL
Substructure

NOTE:

For **VERTICAL SIDING INSTALLATION**, Perforated Hat Channel must be used to allow airflow and drainage of water.

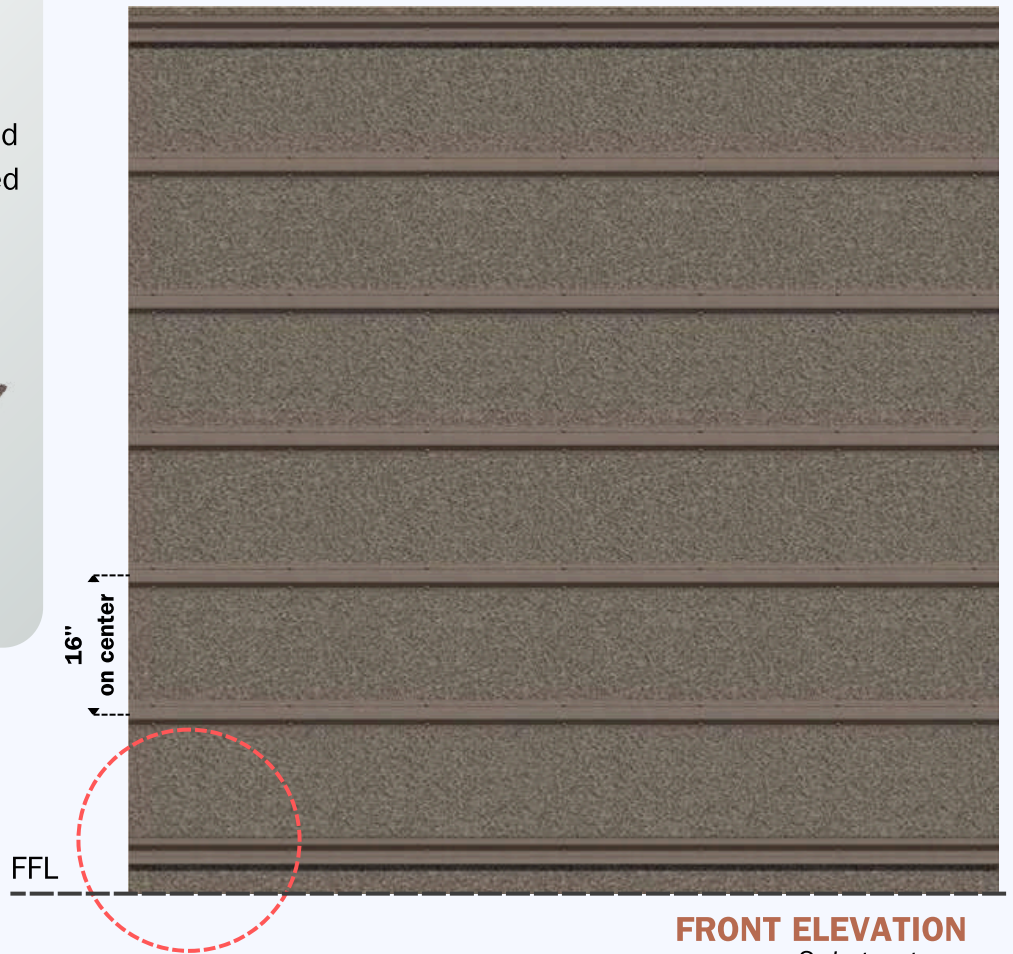

FRONT ELEVATION
Substructure
Siding 6" & 4"
Quik-Trim System

NOVANO Siding Boards require a **minimum of 3"** from the ground to the start of the Siding Board in both horizontal and vertical installations. Plan the batten substructure and wall assembly accordingly to accommodate siding installation while adhering with local building code requirements.

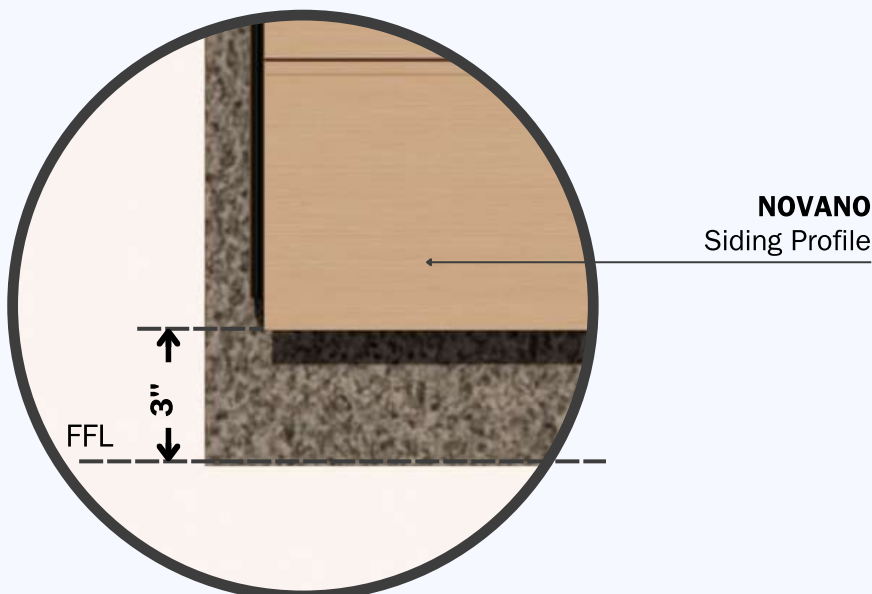

DETAIL
Substructure



NOVANO Aluminum Batten Substructure

Install the battens and secure them to the frame substructure in compliance with local building codes. Ensure that the installed battens do not exceed the “Batten Spacing Requirements” of *Table 1.2*. On walls where two Siding Boards will be used end-to-end, a minimum of two battens must be used to accommodate the fastening of the Siding Boards and any trim pieces desired to the batten substructure where the boards meet. Prior to installing the NOVANO Siding Boards, ensure that the batten installation provides a minimum $\frac{3}{4}$ ” air gap behind the Siding Boards and there is sufficient support for all Siding Boards and trim accessories. This is often achieved through the installation of battens with a minimum thickness of $\frac{3}{4}$ ”

Battens should be installed on top of a code-compliant sheathing with fasteners and fastener spacing sufficient to accommodate all loads imposed upon it by the NOVANO Siding Board, trim components, and any other accessories attached to the battens. NOVANO Siding Boards must be attached to aluminum battens with NOVANO Shoulder stainless steel screws (NV-SIDAC-25-SS Screw) taking care to not penetrate the weather barrier. If the weather barrier is going to be penetrated reference the weather barrier manufacturer’s recommendations. Notes on NOVANO Shoulder Screw NV-SIDAC-25-SS.



SECTION 2 - TRIM AND ACCESSORY OPTIONS

Aluminum Siding Trim systems made for NOVANO Siding Boards are recommended for covering the ends and gaps of Siding Boards.

Suggested supply includes, but is not limited to:

Quik-Trim Outside Corner Trim

(for Inside Corner of Board Installation),



Quik-Trim Inside Corner Trim

(for Inside Corner of Board Installation),



Siding Starter J-Strip

(to start Siding Boards),



Quik-Trim H-Channel Trim

(to cover wall gaps),



Quik-Trim J-Channel Trim & Window J-Channel Trim *(used for Siding Board termination).*



Aluminum Quik-Trim Siding Trims are standard aluminum alloy 6063 T5 and have a .050" nominal wall thickness. Aluminum Siding Trims come in 10' lengths and shall have a standard Mill Finish for field priming and painting unless otherwise specified.

GENERAL INSTALLATION GUIDELINES

for NOVANO Aluminum Quik-Trim Siding

Aluminum Quik-Trim Siding Trim must be cut with a 150-tooth carbide-tip blade for nonferrous metal. Blade Lubricant must be applied to the blade before each cut and the lubricant should be cleaned from the trim prior to installation. None of the Siding Trim should be installed horizontally unless weep holes are drilled at 8" intervals to allow for moisture to escape from behind the face flange. Exceptions to this are 1) a Siding Starter J-Strip installed in any direction and 2) a Quik-Trim Siding J-Channel Trim when it is installed horizontally with its face flange pointing down.

ALUMINUM BATTEN INSTALLATION GUIDELINES

for NOVANO Aluminum Quik-Trim Siding

When using metal battens, either steel or aluminum, it is recommended to use the shoulder SS Screw NV-SIDAC-25-SS which can be driven through the aluminum siding trim and into the metal batten. The trim should be fastened 16" on the center for either horizontal or vertical installations. If the batten substructure spacing is reduced for the Siding Boards the trim should be fastened at the same interval as the siding. Be aware of fastener placement for the siding trim so as to not hinder the installation of the NOVANO Siding Boards.



SECTION 3 - HORIZONTAL SIDING APPLICATION

SECTION 3.1

Pre-apply the Quik-Trim PVC Base for all finishing trim accessories such as trim around corners, windows, and doors according to the pre-plan layout and following the manufacturer's recommendations. Ensure that all trim is level and square. Battens should be installed vertically.

SECTION 3.2

An aluminum Siding Starter J-Strip is required to install the NOVANO Siding Board. Attach the Starter J-Strip at the bottom of the battens following the fastener and spacing recommendations in *Section 2*.

The NOVANO Siding Boards will hang $\frac{1}{2}$ " below the bottom of the Starter J-Strip therefore the Starter J-Strip should be attached accordingly as per the pre-plan layout.

Reverse
HTC3410
Siding Hat Channel

SVJS10
Siding Starter J-Strip

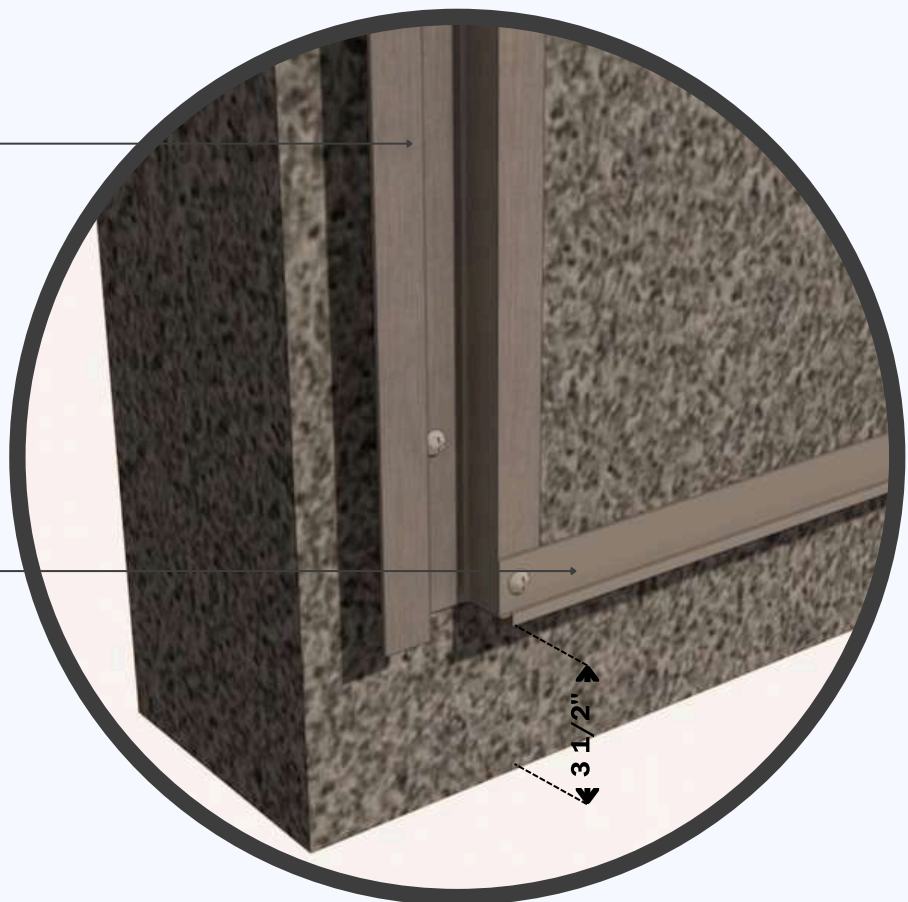

DETAIL
Siding Starter J-Strip
Siding 6" & 4" Quik-Trim System

SECTION 3 - HORIZONTAL SIDING APPLICATION

SECTION 3.3

The Quik-Trim PVC Base should be installed at every end of the reverse hat channel and on top of all the hat channels, by screwing on the PVC Base on its groove.

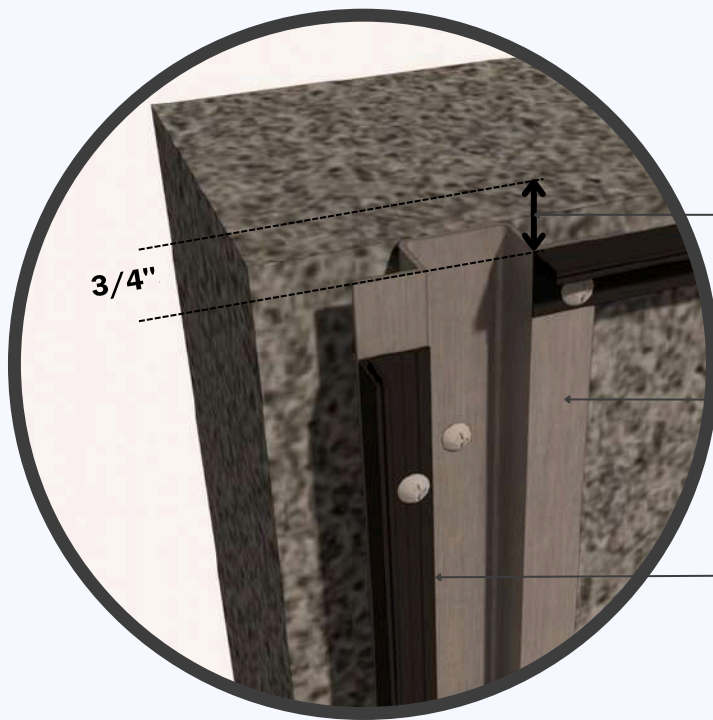

3/4" GAP to adjacent surface to attain **1/2" Finish GAP** for Cross Ventilation

Reverse **HTC3410** Siding Hat Channel

Quik-Trim PVC Base

DETAIL
PVC Base
Siding 6" & 4" Quik-Trim System



FRONT ELEVATION
Siding 6" & 4"
Quik-Trim System

SECTION 3 - HORIZONTAL SIDING APPLICATION

SECTION 3.4

Hook the groove end of the first Siding Board into the Siding Starter J-Strip.

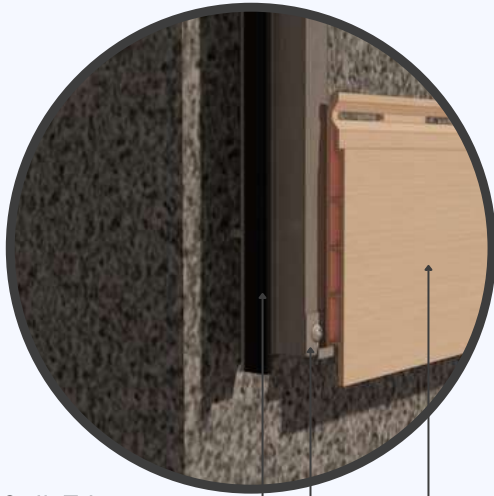

Quik-Trim
PVC Base

SVSJ10
Siding Starter J-Strip

NOVANO
Siding Profile

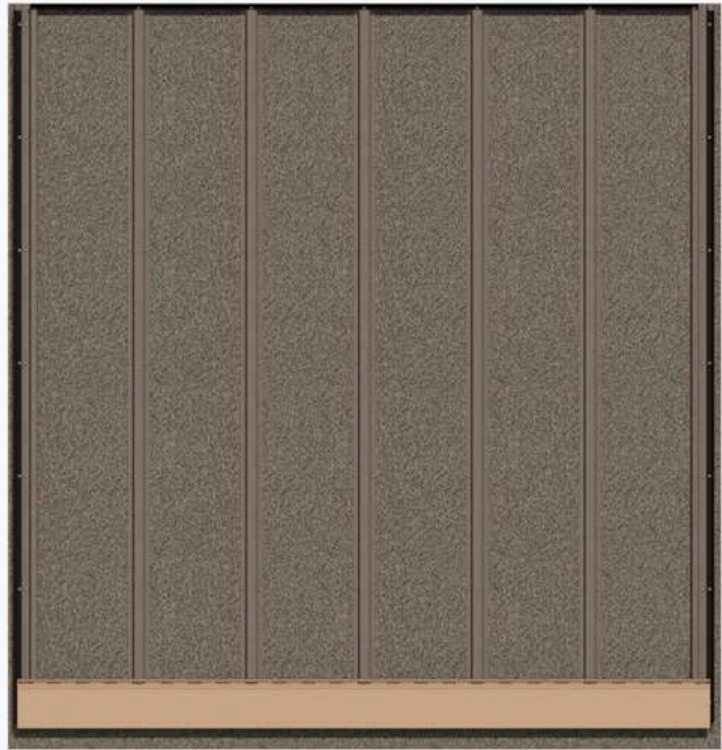

FRONT ELEVATION

*Siding 6" & 4"
Quik-Trim System*



DETAIL 1

Slide down the first NOVANO Siding Board into Siding Starter J-Strip.

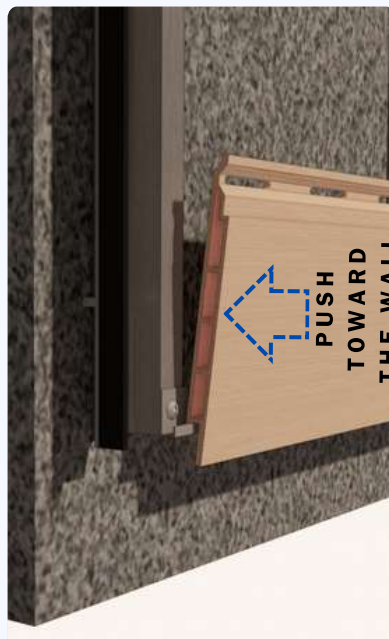

DETAIL 2

Hook the groove end of the first NOVANO Siding Board into the Siding Starter J-Strip with SS screw.



DETAIL 3

Push the NOVANO Siding Board perpendicular into the runner and screw direct to the groove.



SECTION 3 - HORIZONTAL SIDING APPLICATION

SECTION 3.5

Install the shoulder SS screws NV-SIDAC-25-SS into all slotted holes except the center hole. DO NOT over-tighten the screws. The screws should be placed in the center of the slotted hole and loose enough to allow the board to move freely from side to side to allow for expansion and contraction.

HTC3410

Siding Hat Channel

NV-SIDAC-25-SS

Shoulder SS Screw

NOVANO

Siding Profile

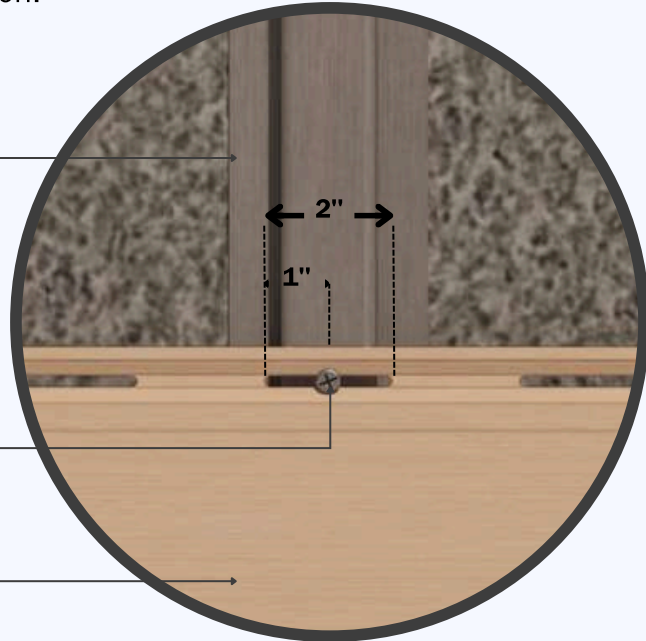

DETAIL

Siding 6" & 4" Quik-Trim System

No Screw

NV-SIDAC-25-SS
Shoulder SS Screw

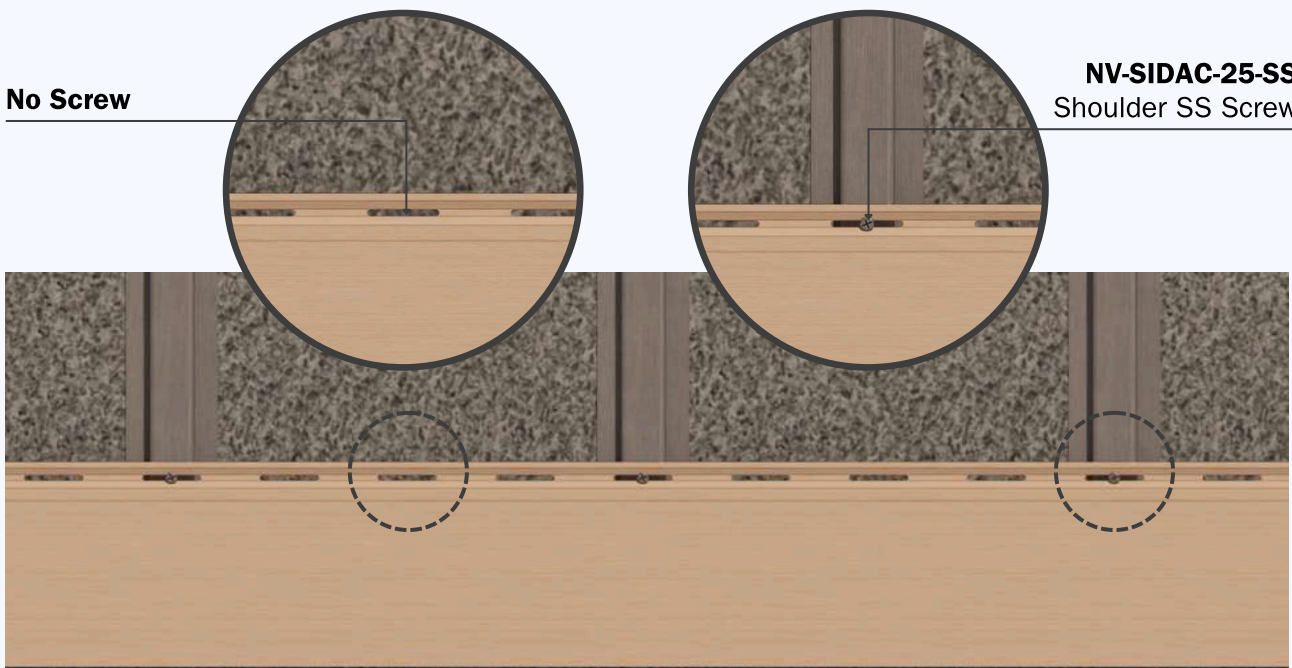

FRONT ELEVATION

Siding 6" & 4"
Quik-Trim System

NOTE:

If installing more than one board in width, please refer to Section 4 – Horizontal Multi Board Siding Applications.

SECTION 3 - HORIZONTAL SIDING APPLICATION

SECTION 3.6

Install the final two NV-SIDAC-25-SS screws in the slotted hole in the center of the board. This will allow for expansion and contraction evenly to each side of the assembly. Check the instruction pinning location in *Section 8*.

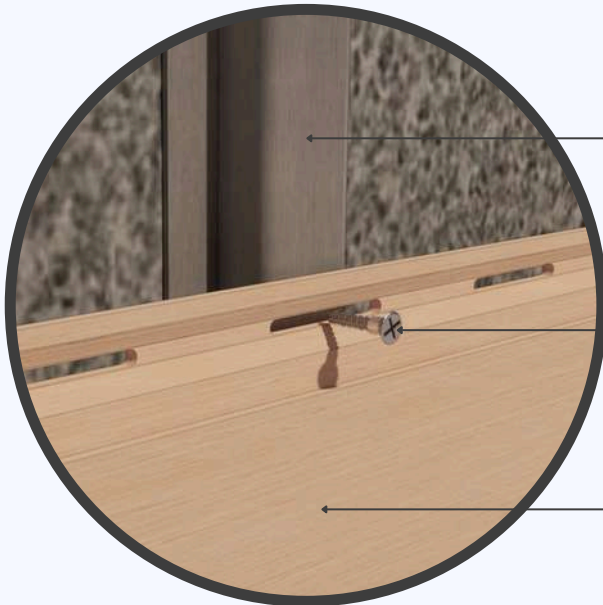

HTC3410
Siding Hat Channel

NV-SIDAC-25-SS
Shoulder SS Screw

NOVANO
Siding Profile

DETAIL

Siding 6" & 4" Quik-Trim System

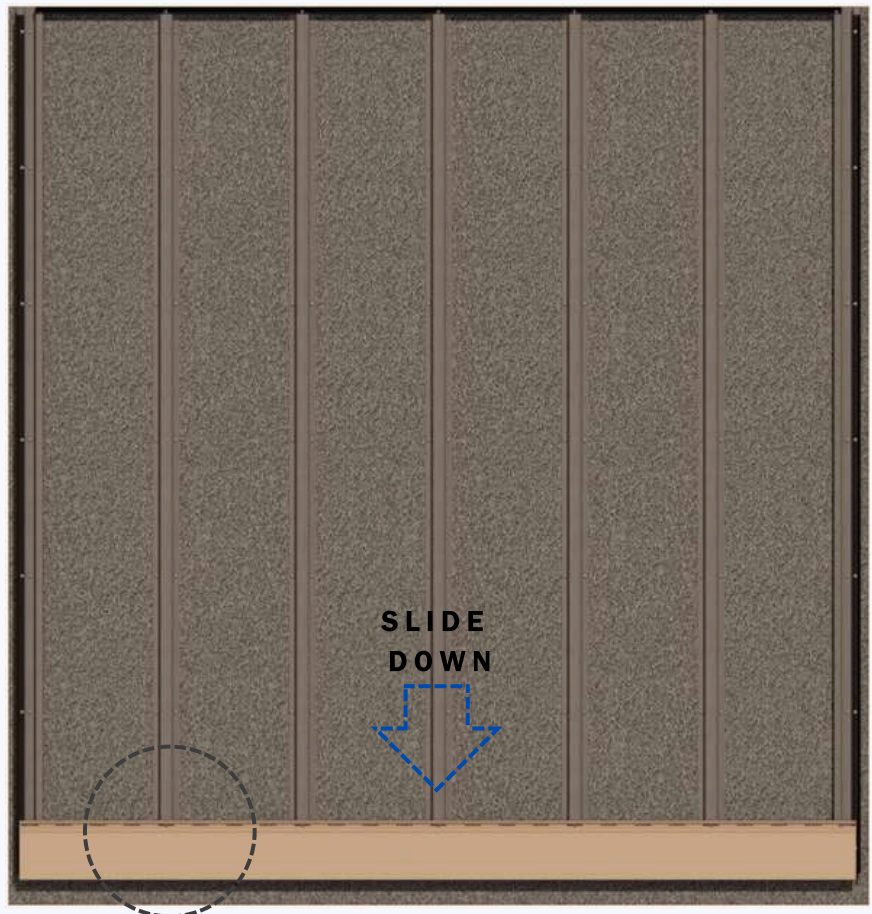

FRONT ELEVATION
Siding 6" & 4"
Quik-Trim System

Quik-Trim
PVC Base

NV-SIDAC-25-SS
Shoulder SS Screw

NOVANO
Siding Profile

Reverse
HTC3410
Siding Hat Channel

**NOVANO Siding Board
Interlock Connection**

**SLIDE
DOWN**

**SLIDE
DOWN**

DETAIL

Siding 6" & 4" Quik-Trim System

FRONT ELEVATION

Siding 6" & 4"
Quik-Trim System



SECTION 3 - HORIZONTAL SIDING APPLICATION

SECTION 3.7

Hook the groove end of the next board onto the tongue of the installed Siding Board.

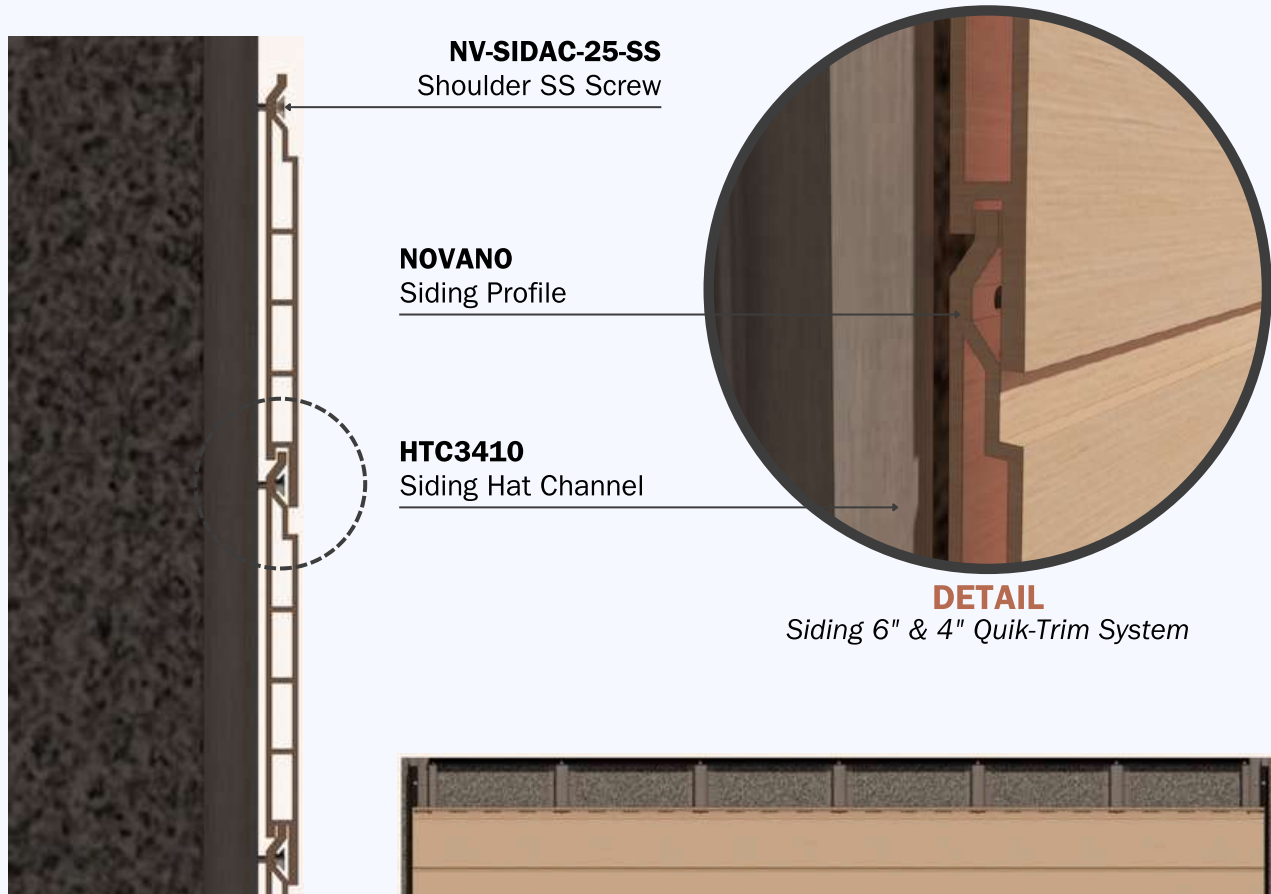

SECTION
Siding 6" & 4"
Quik-Trim System

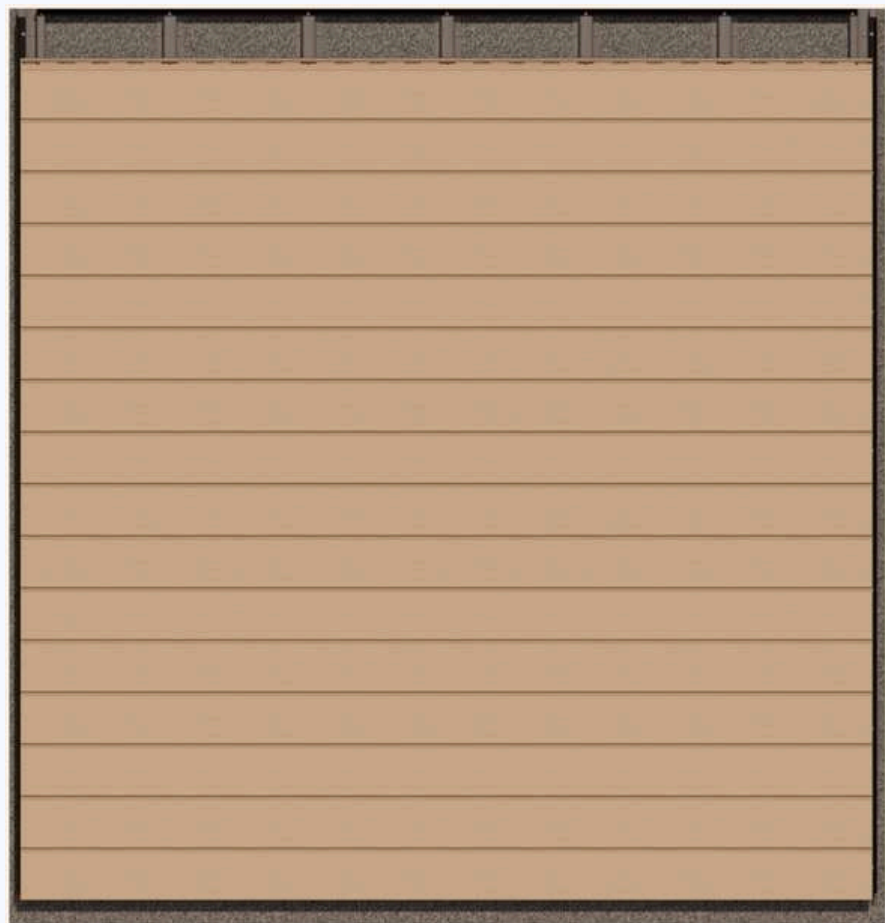

FRONT ELEVATION
Siding 6" & 4"
Quik-Trim System



SECTION 3 - HORIZONTAL SIDING APPLICATION

SECTION 3.8

Continue installing the Siding Boards as outlined in Section 3. Saw-off the last Siding Board into size to complete the installation.

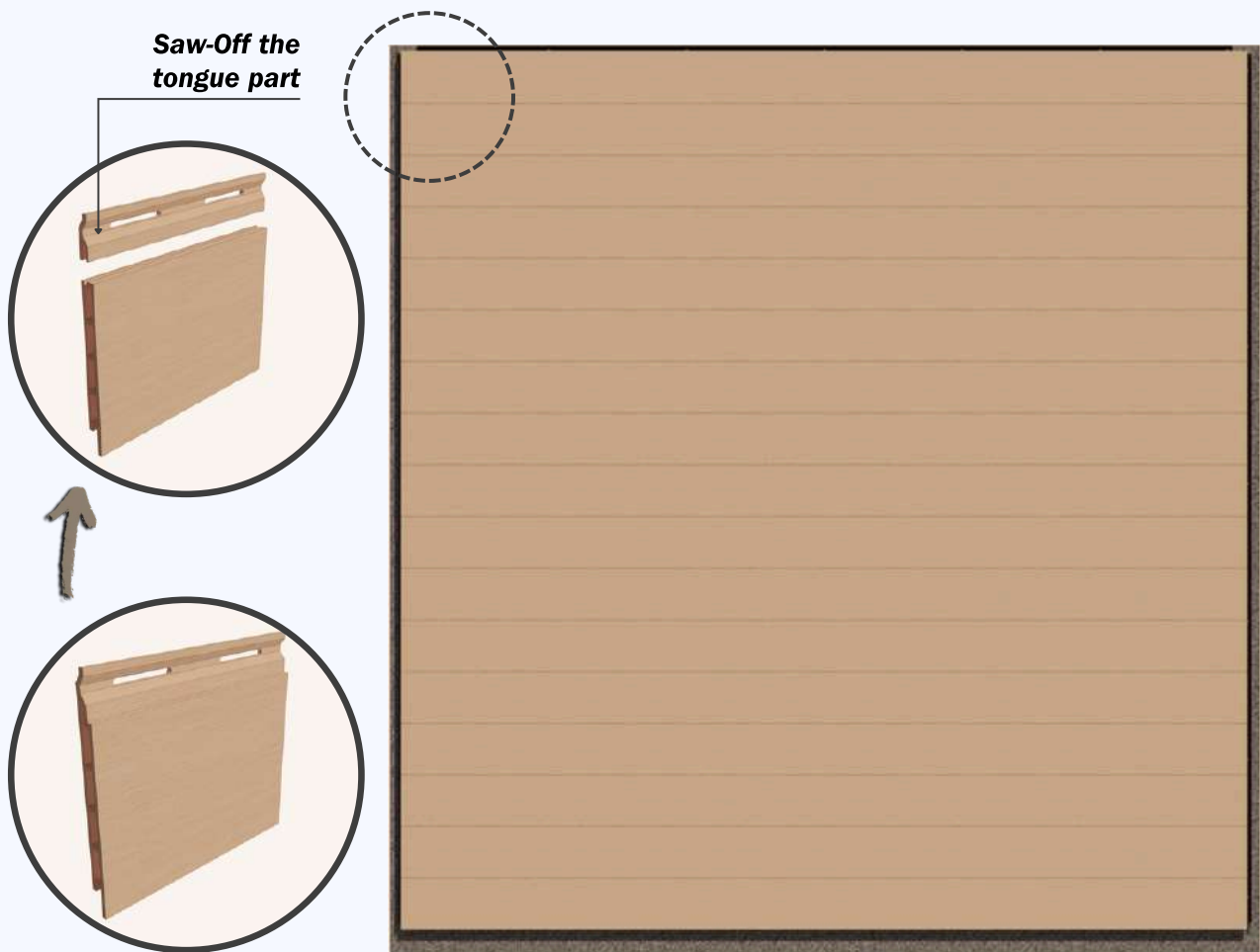
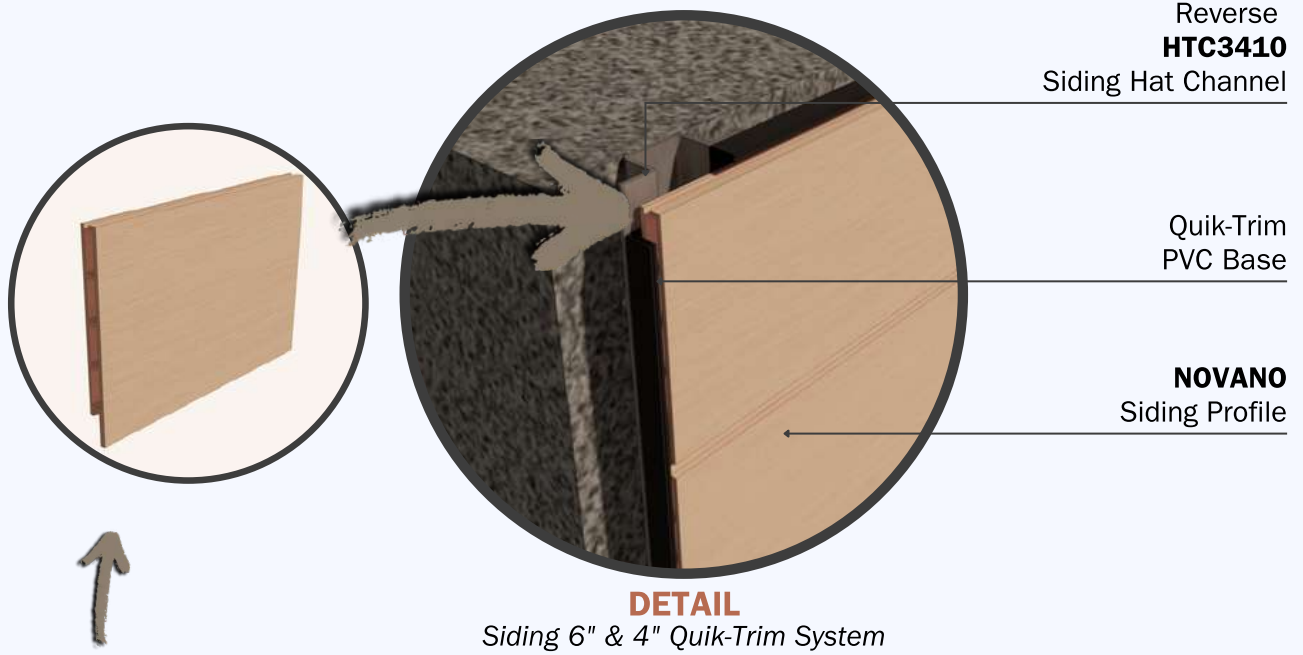

SECTION 3 - HORIZONTAL SIDING APPLICATION

SECTION 3.9

After the installation of the last NOVANO Siding Board, the exposed siding edges will be finished by installing the aluminum Quik-Trim.

And finally, install the Window J-Mold into the PVC Base on the sides and J-Mold into the topmost part.

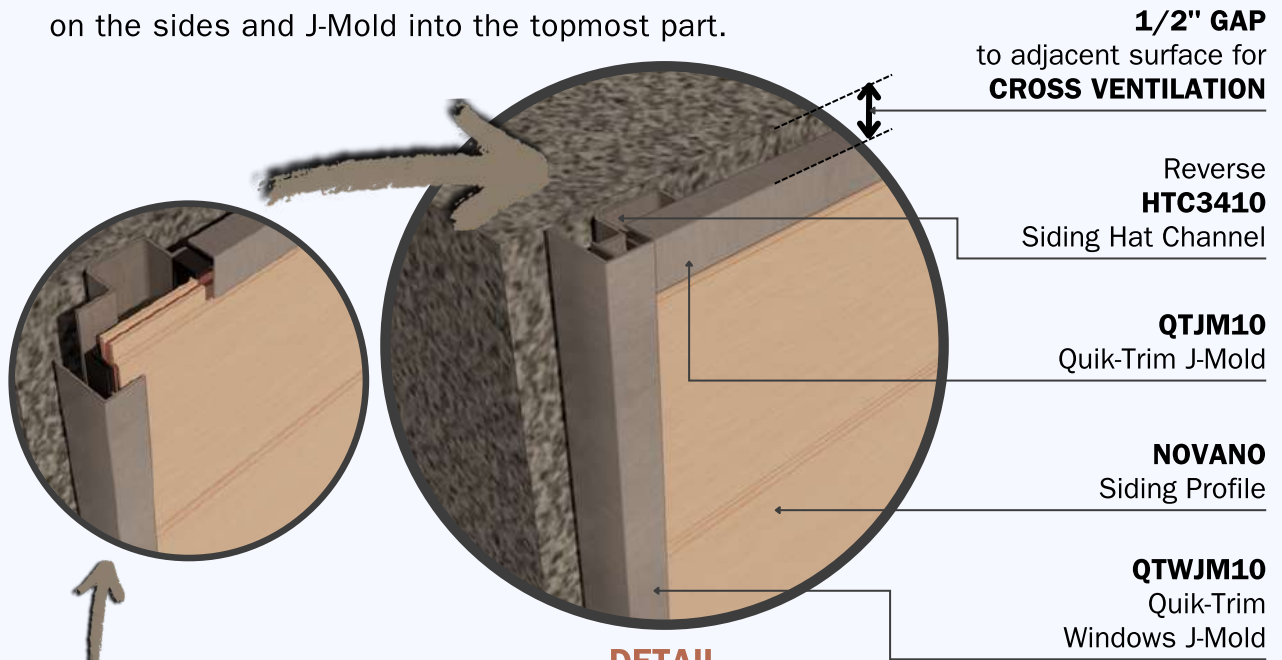

DETAIL

Siding 6" & 4" Quik-Trim System

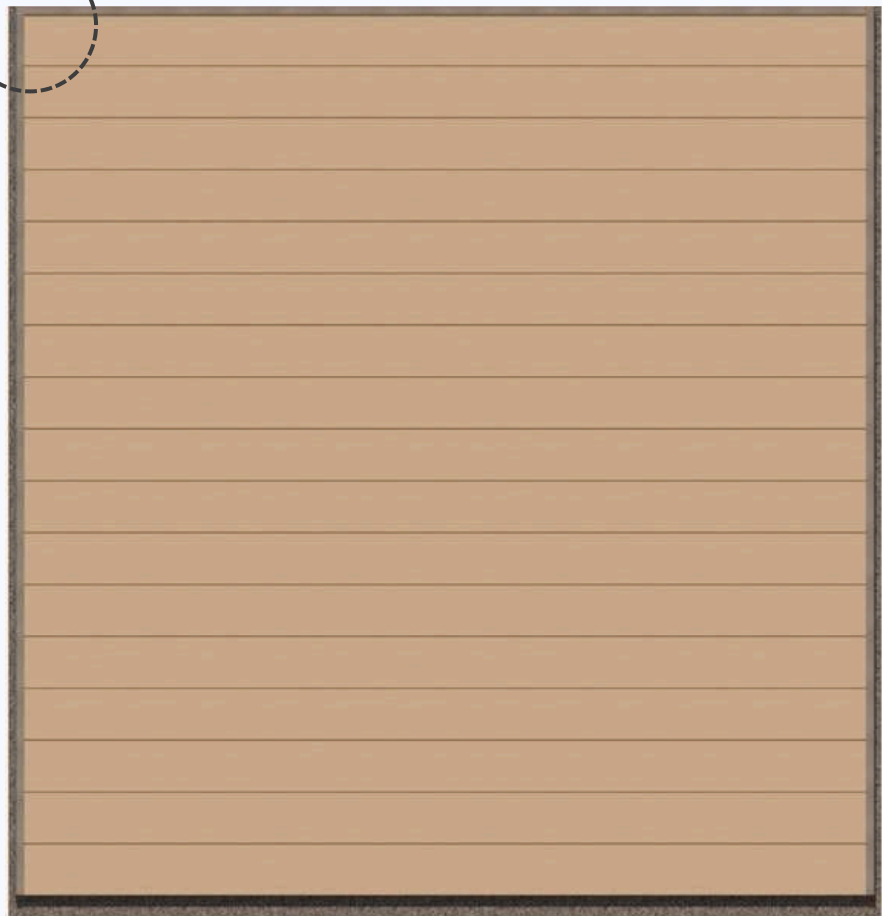

FRONT ELEVATION

Siding 6" & 4"
Quik-Trim System

**Install the
Window J-Mold
into the PVC Base**



SECTION 4 - MULTI-BOARD HORIZONTAL SIDING APPLICATION

2 Board Wide Installation WITHOUT the Aluminum Quik-Trim H-Mold (24ft max width)

SECTION 4.1.1

Ensure that two battens have been installed where boards are to be installed end to end.

SECTION 4.1.2

Follow **Steps 3.1, 3.2, and 3.3** from *Section 3* to install the finishing trim, Siding Starter J-Strip, and hook in the 1st Siding Board.

SECTION 4.1.3

Install NV-SIDAC-25-SS screws into all slotted holes except the hole closest to the abutted joint on both Siding Boards. DO NOT over-tighten the screws. The screws should be placed in the center of the slotted hole and loose enough to allow the board to move freely from side to side to allow for expansion and contraction.

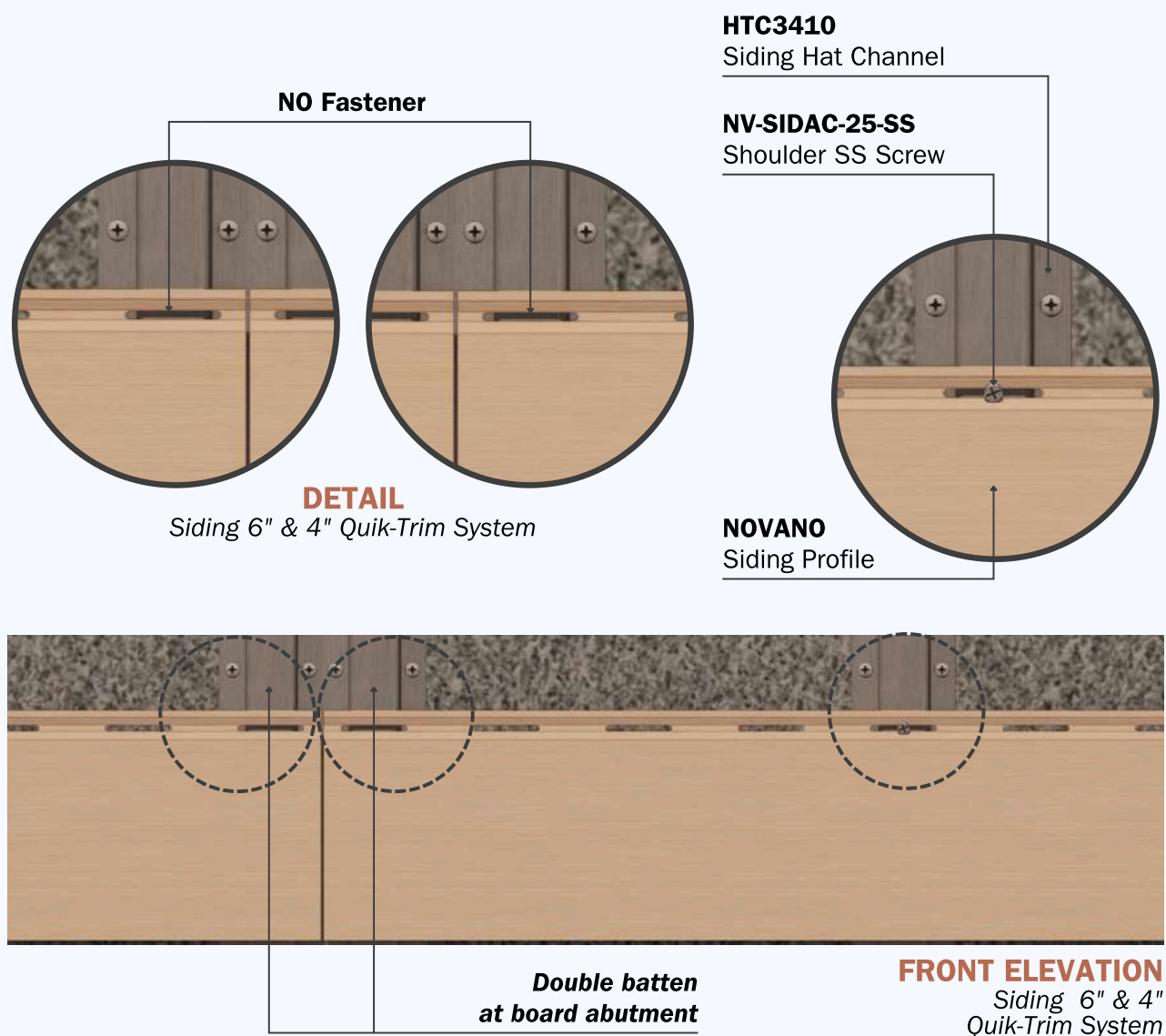

SECTION 4 - MULTI-BOARD HORIZONTAL SIDING APPLICATION

2 Board Wide Installation WITHOUT the Aluminum Quik-Trim H-Mold (24ft max width)

SECTION 4.1.4

Install one NV-SIDAC-25-SS screw in the slotted hole closest to the abutted joint on both Siding Boards. This will control expansion and contraction evenly to the outside of the Siding Boards while keeping the abutting joint snug.

NV-SIDAC-25-SS
Shoulder SS Screw

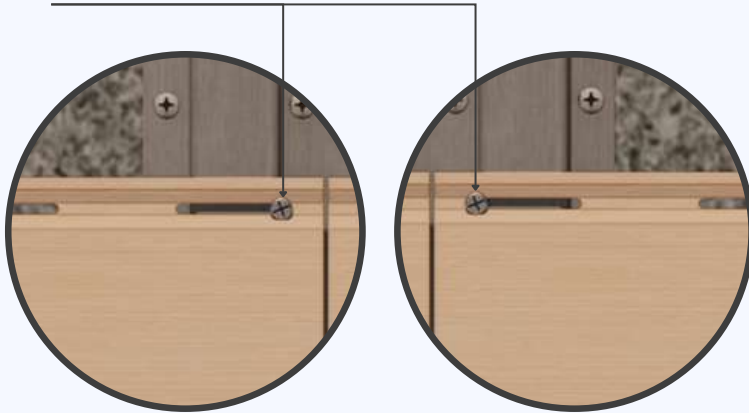

DETAIL
Siding 6" & 4" Quik-Trim System

HTC3410
Siding Hat Channel

NV-SIDAC-25-SS
Shoulder SS Screw

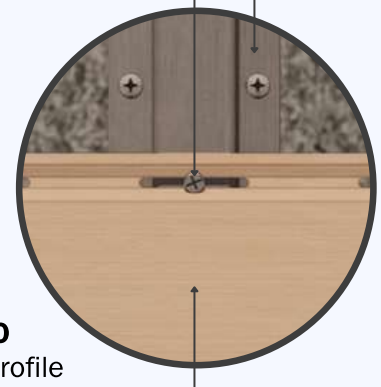

NOVANO
Siding Profile

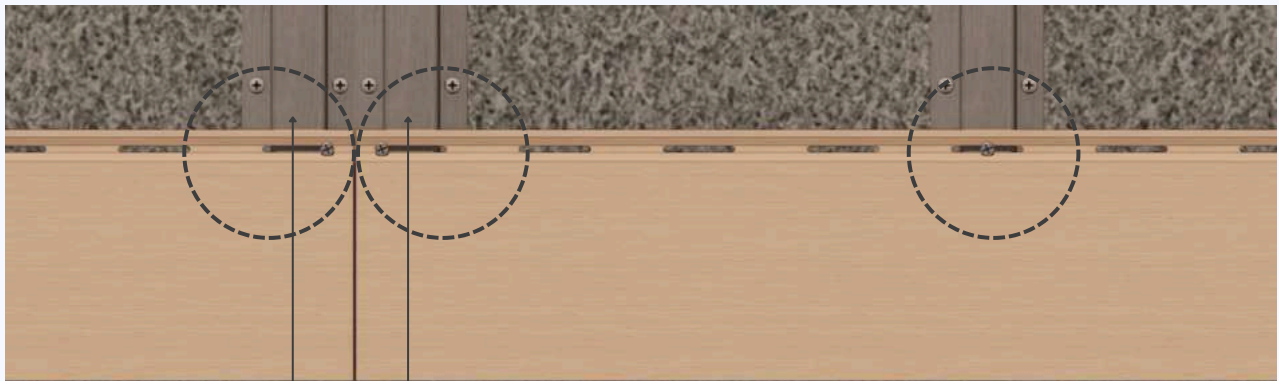

**Double batten
at board abutment**

FRONT ELEVATION
Siding 6" & 4"
Quik-Trim System

SECTION 4.1.5

Hook the groove end of the next board onto the tongue of the installed Siding Board.

SECTION 4.1.6

Continue installing Siding Boards as outlined in Section 4: "2 Board Wide Installation without the Aluminum Quik-Trim H-Mold" and follow **Steps 3.8 and 3.9** in Section 3 to finish the installation.

SECTION 4 - MULTI-BOARD HORIZONTAL SIDING APPLICATION

Multi-Board Wide Installation using Continuous Aluminum Quik-Trim H-Mold

SECTION 4.2.1

Follow **Steps 3.1, 3.2 and 3.3** from *Section 3*.

SECTION 4.2.2

Install the Quik-Trim PVC Base into the hat channel where the aluminum Quik-Trim H-Mold will be installed.

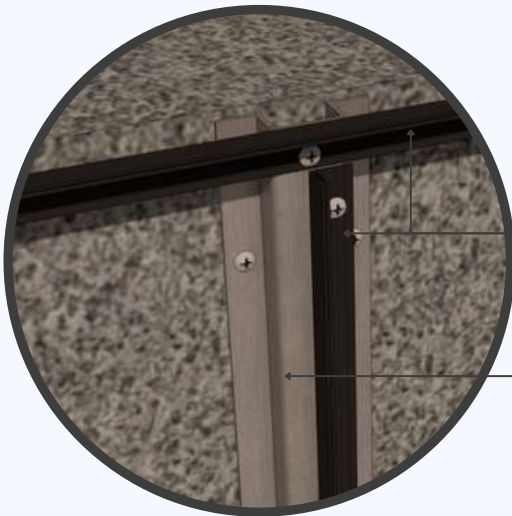

Quik-Trim
PVC Base

HTC3410
Siding Hat Channel

DETAIL
Siding 6" & 4"
Quik-Trim System

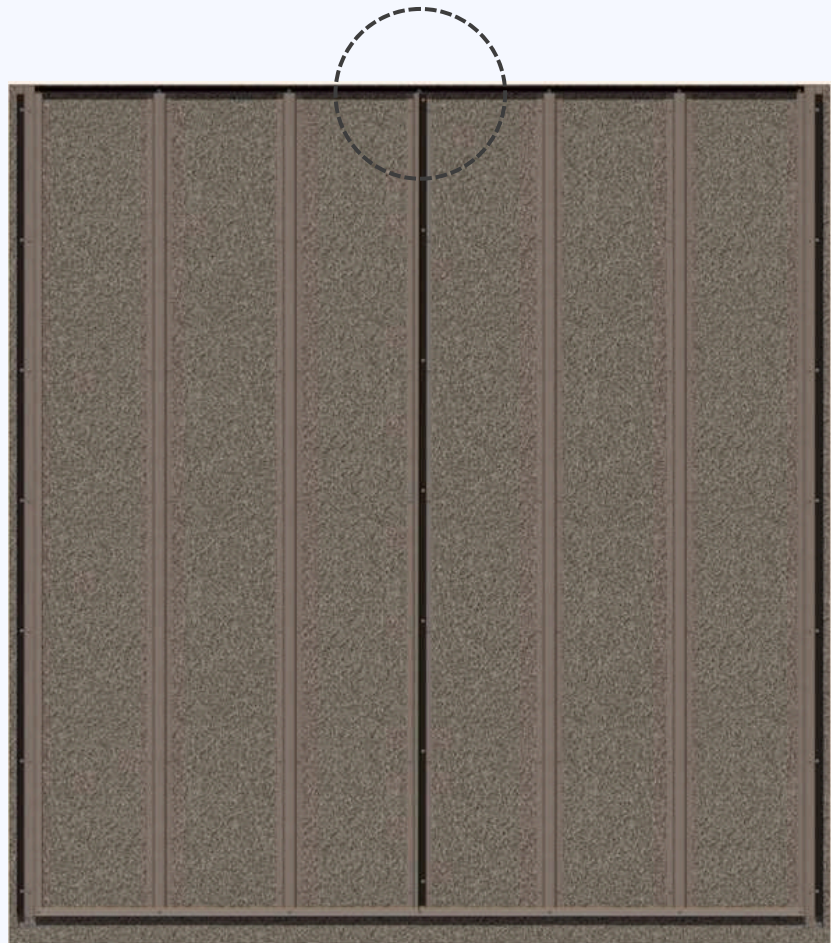

FRONT ELEVATION
Siding 6" & 4"
Quik-Trim System

SECTION 4 - MULTI-BOARD HORIZONTAL SIDING APPLICATION

Multi-Board Wide Installation using Continuous Aluminum Quik-Trim H-Mold

SECTION 4.2.3

Follow **Steps 3.4, 3.5, and 3.6** of *Section 3* and install NV-SIDAC-25-SS screws or #8 screws into all slotted holes except the center hole. DO NOT over-tighten the screws. The screws should be placed in the center of the slotted hole and loose enough to allow the board to move freely from side to side to allow for expansion and contraction.

HTC3410

Siding Hat Channel

NV-SIDAC-25-SS

Shoulder SS Screw

NOVANO

Siding Profile

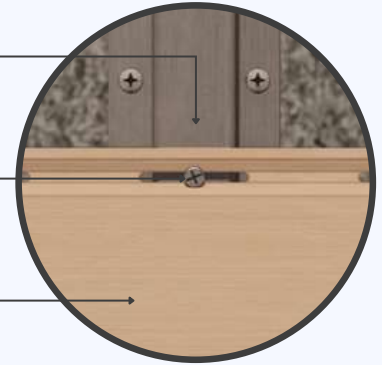

DETAIL

Siding 6" & 4"
Quik-Trim System

Quik-Trim
PVC Base



FRONT ELEVATION

Siding 6" & 4"
Quik-Trim System

SECTION 4.2.4

Install the final two NV-SIDAC-25-SS screws closest to the ends in the slotted hole in the center of the board. This will allow for expansion and contraction evenly to each side of the assembly.



DETAIL

Siding 6" & 4"
Quik-Trim System

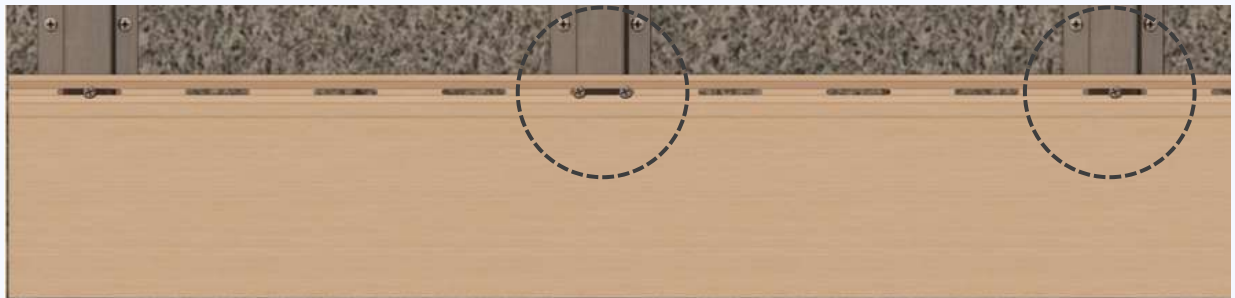

FRONT ELEVATION

Siding 6" & 4"
Quik-Trim System

SECTION 4 - MULTI-BOARD HORIZONTAL SIDING APPLICATION

Multi-Board Wide Installation using Continuous Aluminum Quik-Trim H-Mold

SECTION 4.2.4

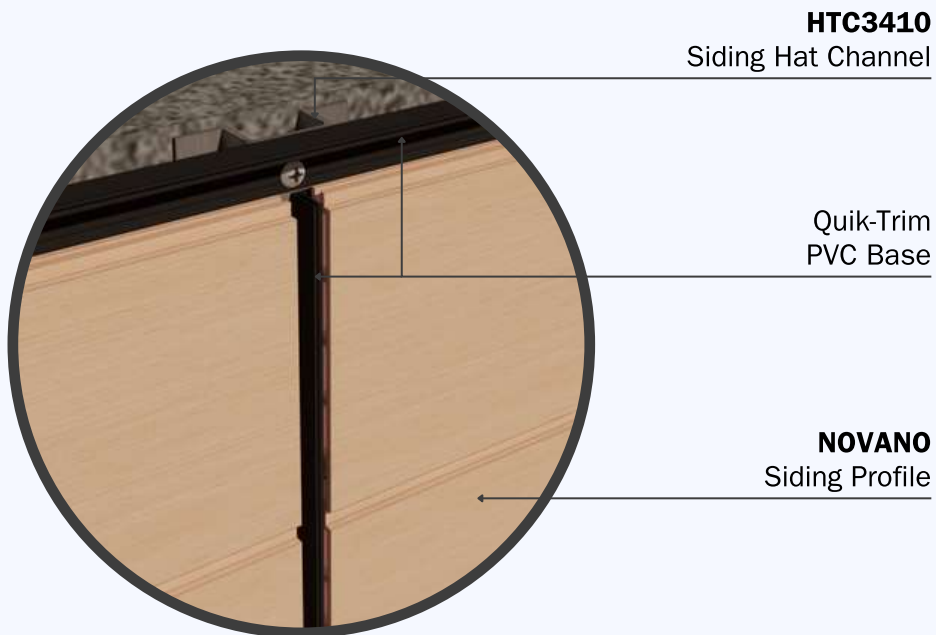

DETAIL
Siding 6" & 4"
Quik-Trim System

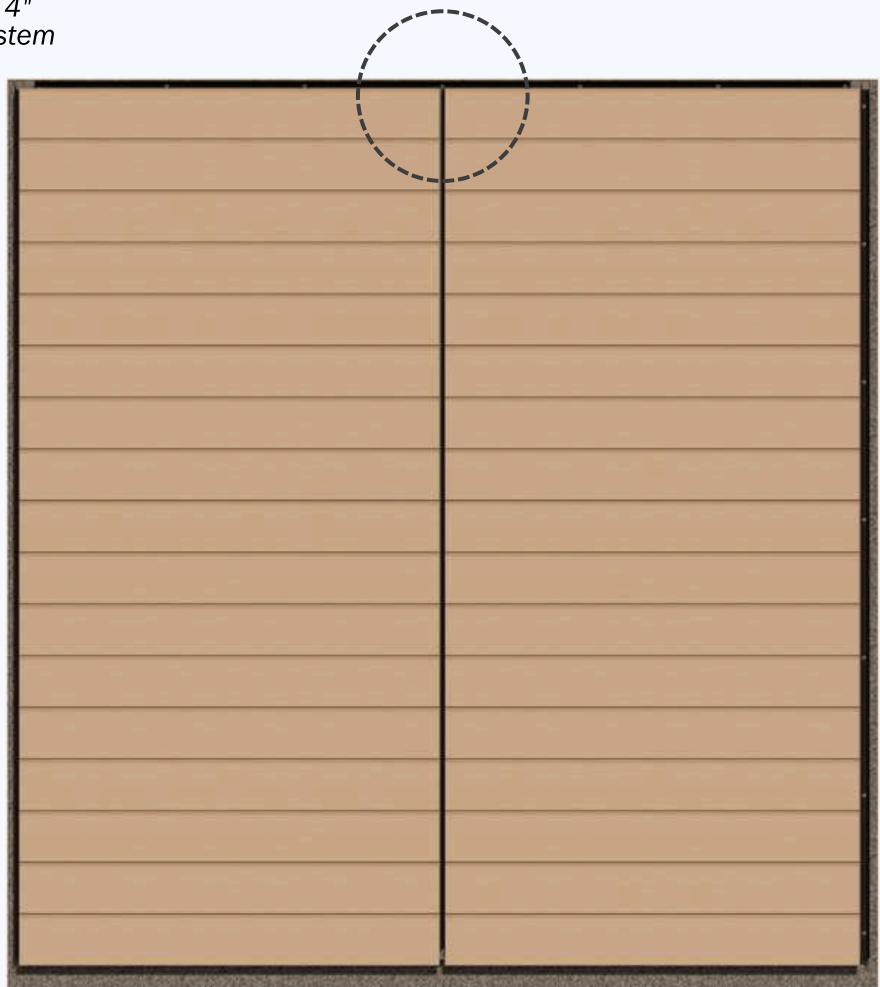

FRONT ELEVATION
Siding 6" & 4"
Quik-Trim System

SECTION 4 - MULTI-BOARD HORIZONTAL SIDING APPLICATION

Multi-Board Wide Installation using Continuous Aluminum Quik-Trim H-Mold

SECTION 4.2.5

After the installation of the last Siding Board, finally install all the aluminum trim on the PVC Base to finish the installation.

1/2" GAP
to adjacent surface for
CROSS VENTILATION

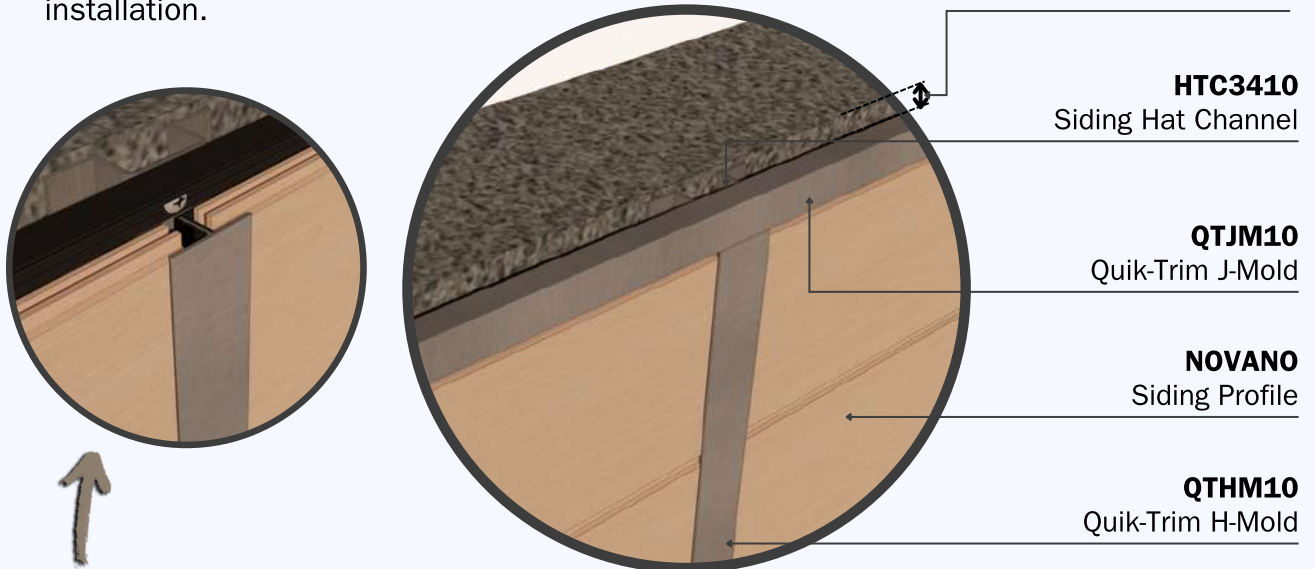

DETAIL
Siding 6" & 4" Quik-Trim System



**Install the
H-Mold
into the PVC Base**

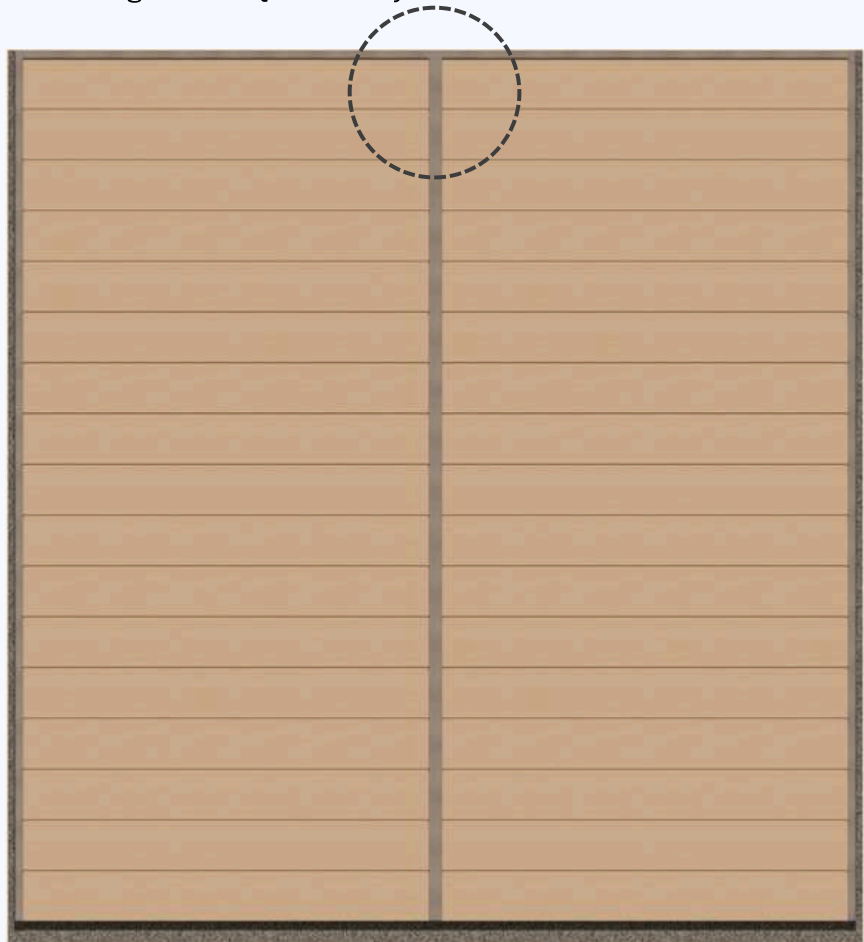

FRONT ELEVATION
Siding 6" & 4"
Quik-Trim System

SECTION 5 - VERTICAL SIDING APPLICATION

SECTION 5.1

Pre-apply the Quik-Trim PVC Base for all finishing trim accessories such as trim around corners, windows, and doors according to the pre-plan layout and following the manufacturer's recommendations. Ensure that all trim is level and square. Battens should be installed horizontally with punched holes.

SECTION 5.2

A Siding Starter J-Strip is required to install the NOVANO Siding Board. Attach the Starter J-Strip vertically at one end of the batten substructure following the fastener and spacing recommendations in *Section 2*.

The NOVANO Siding Boards will hang $\frac{1}{2}$ " beyond the Starter J-Strip therefore the Starter J-Strip should be attached accordingly per the pre-plan layout. If the siding is starting in a corner the corner attachment and the Starter J-Strip should be attached at the same time.

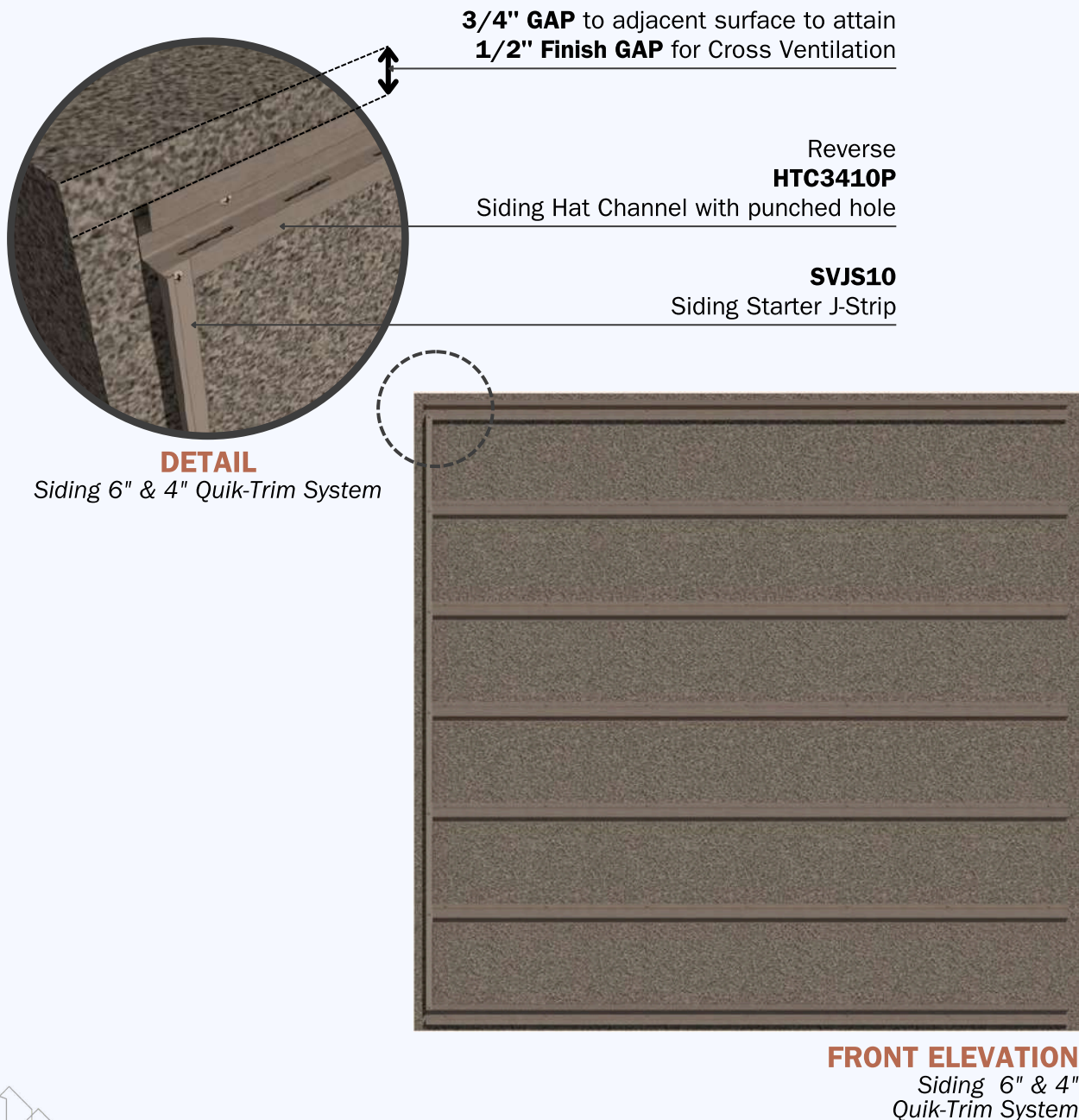

SECTION 5 - VERTICAL SIDING APPLICATION

SECTION 5.3

The Quik-Trim PVC Base should be installed at every end of the reverse hat channel and on side of all the hat channels, by screwing on the PVC Base on its groove.

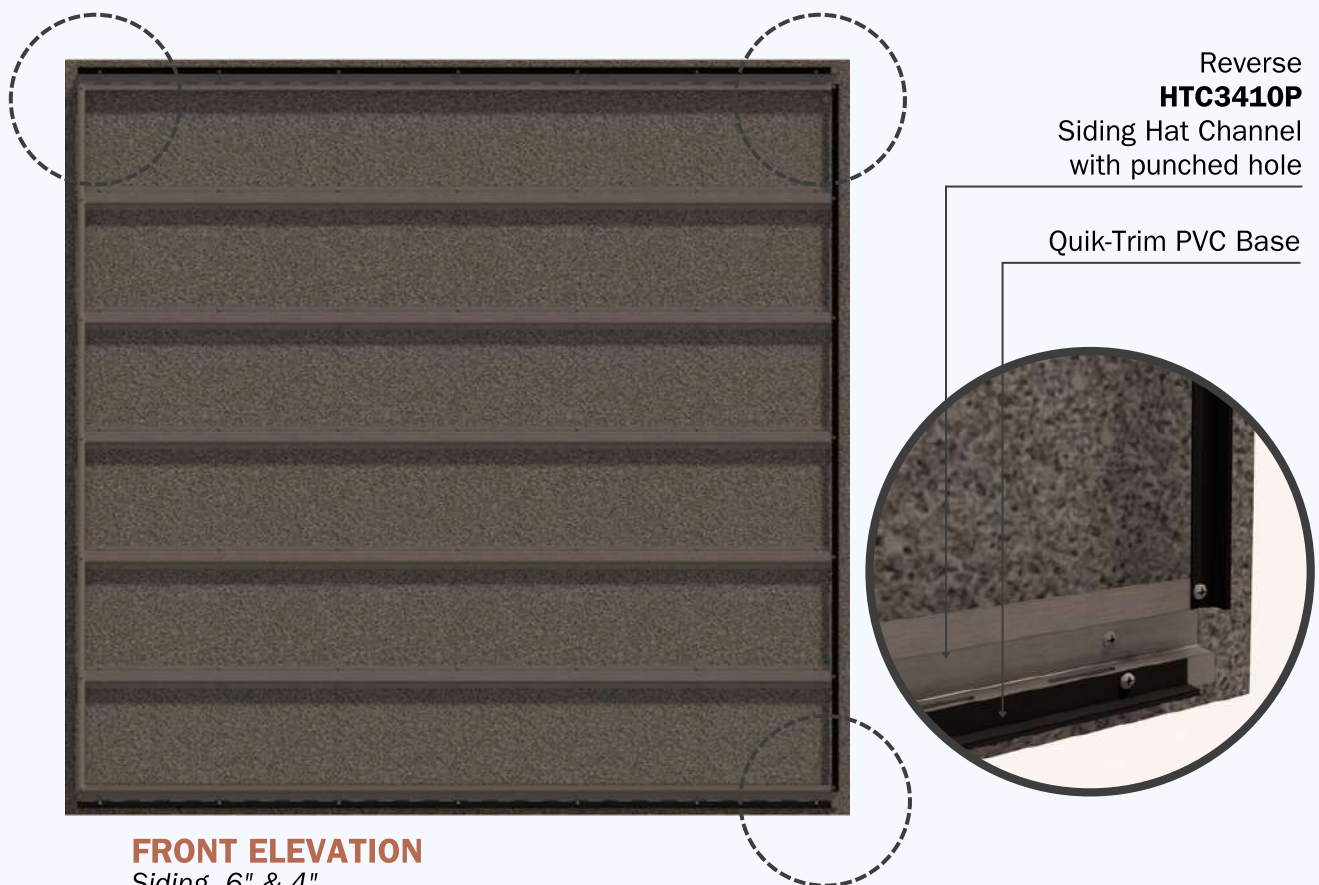
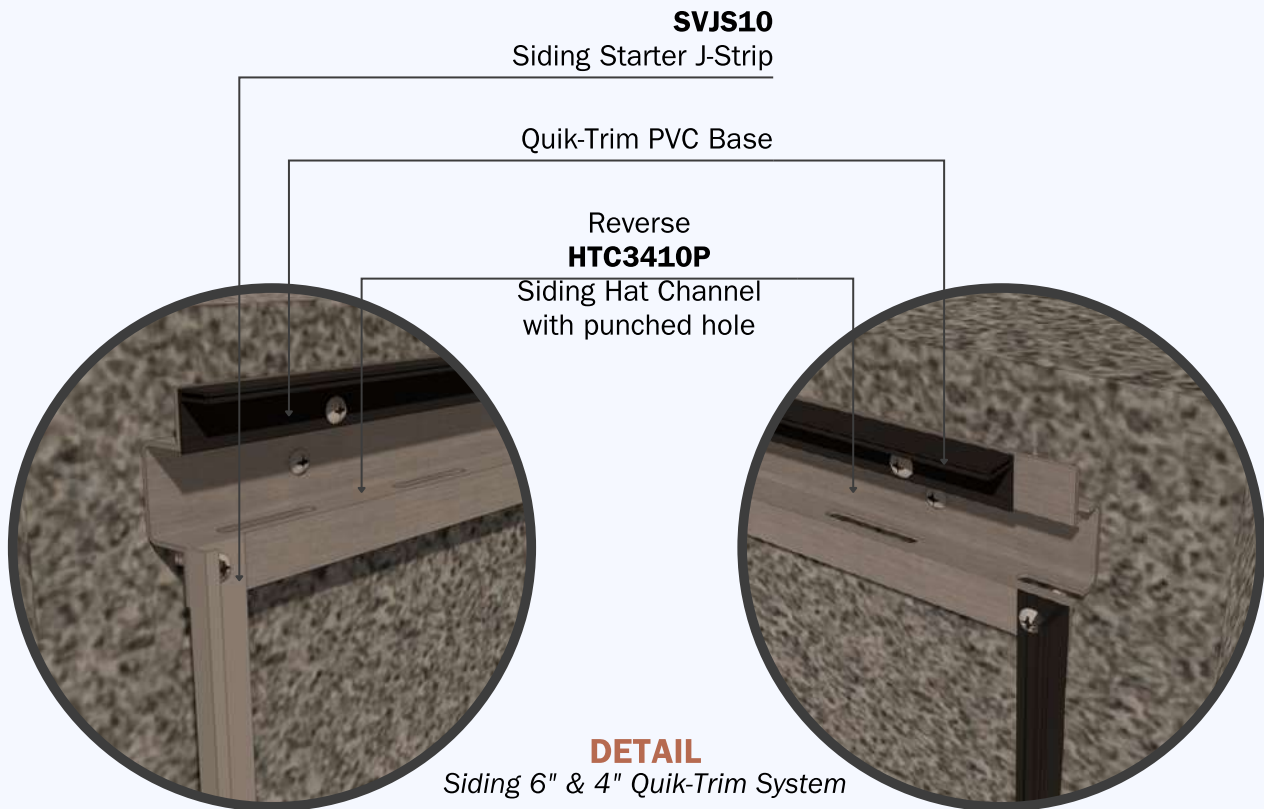

SECTION 5 - VERTICAL SIDING APPLICATION

SECTION 5.4

Hook the groove end of the first Siding Board into the Siding Starter J-Strip vertically.

Reverse
HTC3410P
Siding Hat Channel
with punched hole

SVJS10
Siding Starter J-Strip

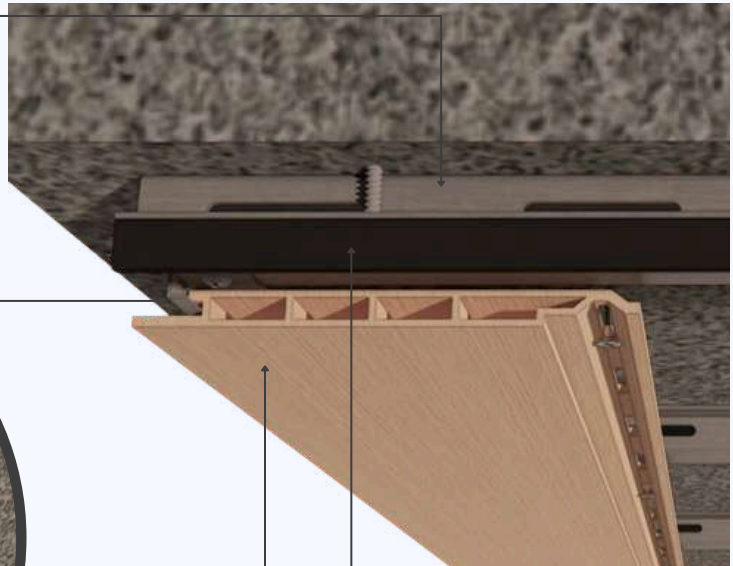

Quik-Trim PVC Base

NOVANO
Siding Profile



DETAIL
Siding 6" & 4"
Quik-Trim System



NOVANO
Siding Profile

SVJS10
Siding Starter J-Strip

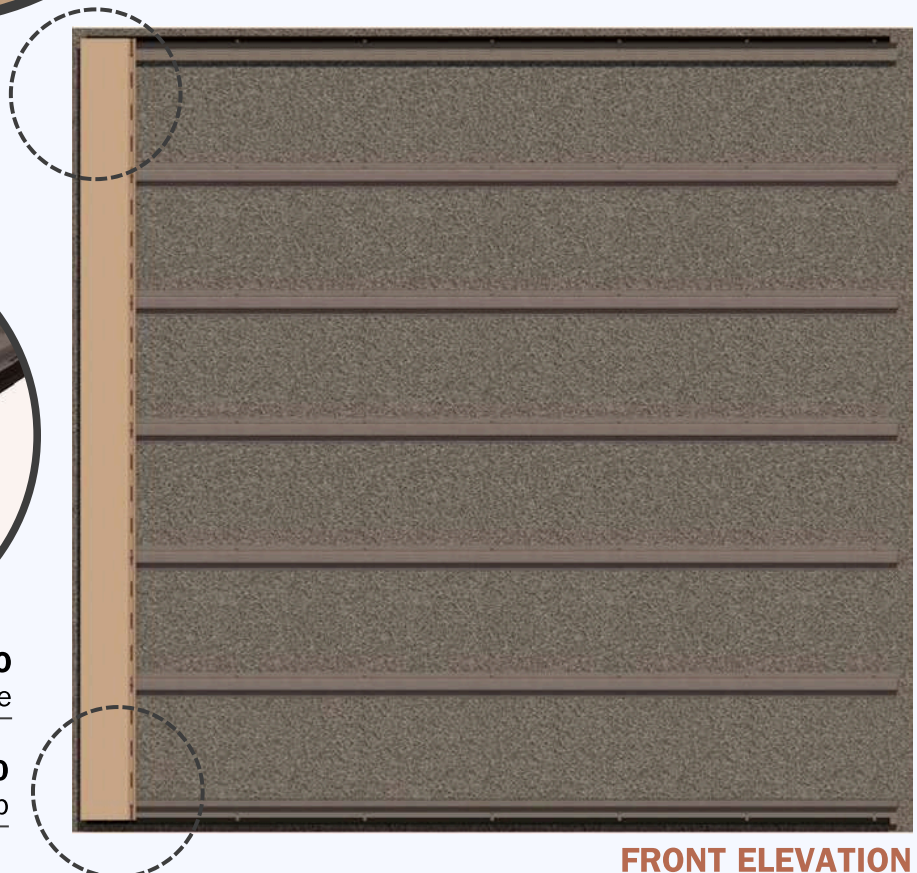

FRONT ELEVATION
Siding 6" & 4"
Quik-Trim System

SECTION 5 - VERTICAL SIDING APPLICATION

SECTION 5.5

Continuously install the Siding Board vertically and install a NV-SIDAC-25-SS screw or a #8 screw into the slotted hole at the top of the Siding Board. DO NOT over-tighten this screw. This screw should be placed at the top of the slotted hole and loose enough to allow the board to move freely in the vertical direction allowing for expansion and contraction.

NOVANO
Siding Profile

NV-SIDAC-25-SS
Shoulder SS Screw

HTC3410P
Siding Hat Channel
with punched hole

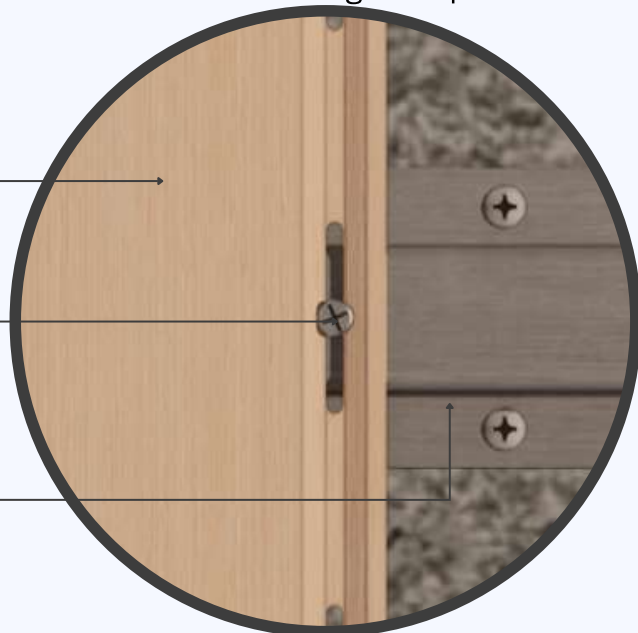

DETAIL

Siding 6" & 4" Quik-Trim System

HTC3410P
Siding Hat Channel
with punched hole

NV-SIDAC-25-SS
Shoulder SS Screw

NOVANO
Siding Profile

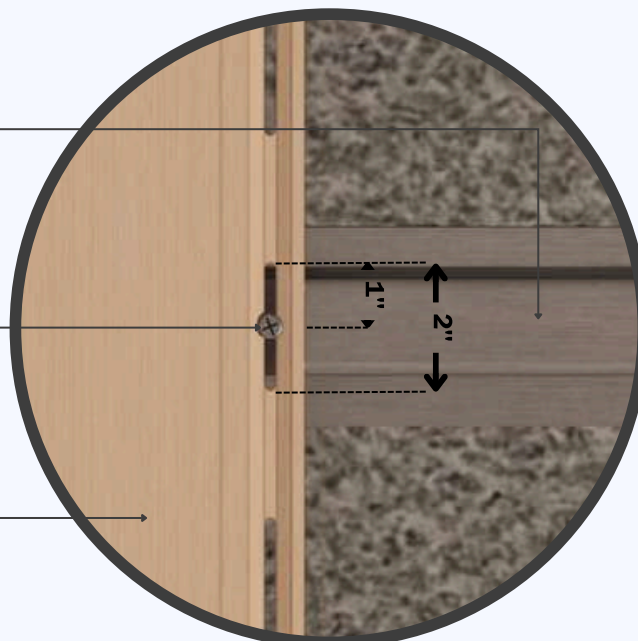

DETAIL

Siding 6" & 4" Quik-Trim System

SPECIAL REQUIREMENT

By following these installation guides for vertical installation methods ALL expansion and contraction will happen at the bottom of the board. Gap the bottom of the board properly based on installation needs.

SECTION 5 - VERTICAL SIDING APPLICATION

SECTION 5.6

Continue installing Siding Boards vertically as outlined in *Section 5* until the last Siding Board is installed.

NOVANO
Siding Profile

Reverse
HTC3410P
Siding Hat Channel
with punched hole

Quik-Trim
PVC Base

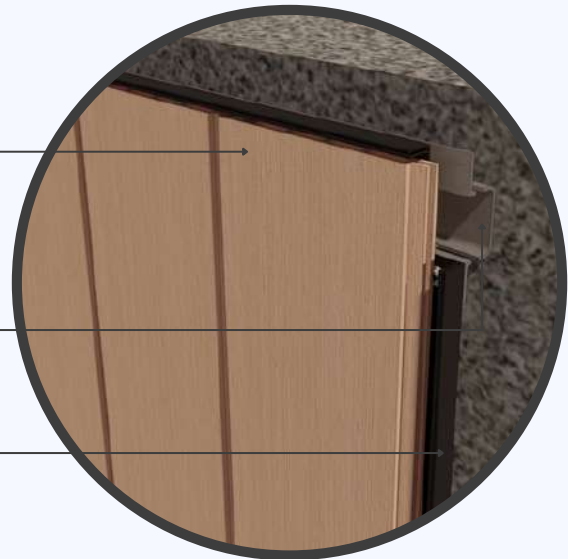

DETAIL

Siding 6" & 4" Quik-Trim System

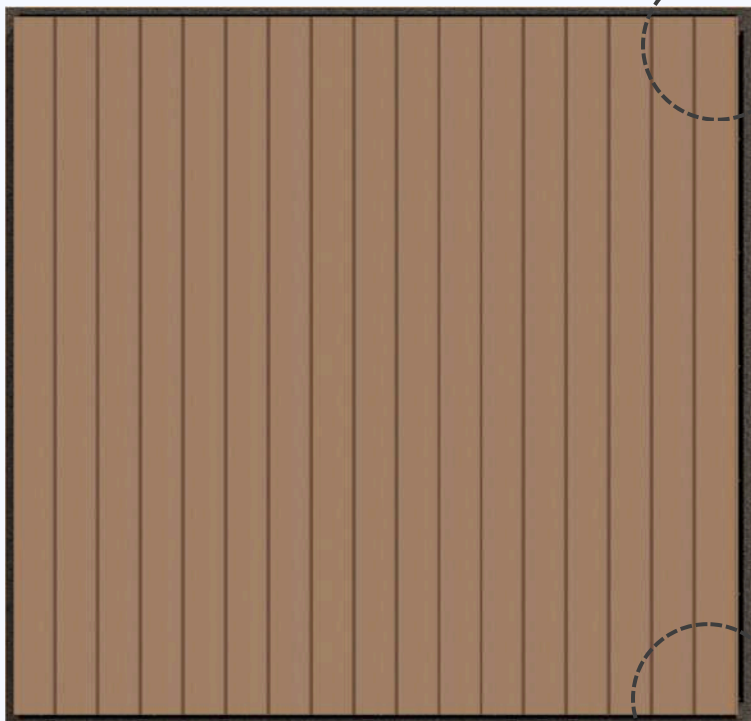

FRONT ELEVATION

Siding 6" & 4"
Quik-Trim System

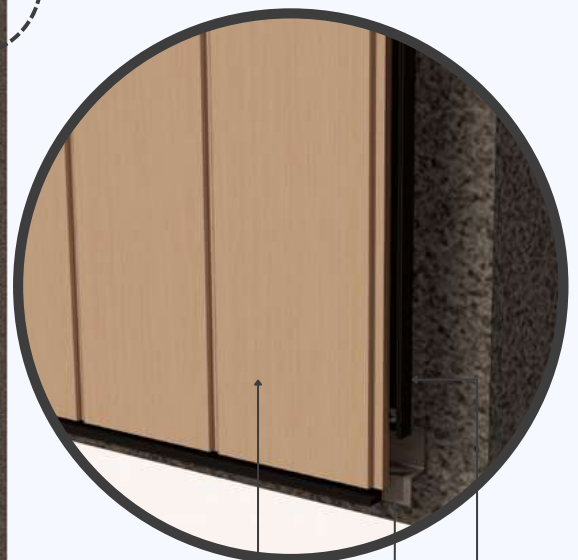

NOVANO
Siding Profile

Reverse
HTC3410P
Siding Hat Channel
with punched hole

Quik-Trim
PVC Base

NOTE:

If installing more than one board in height, please refer to *Section 6 – Vertical Multi-Board Siding Applications*



SECTION 5 - VERTICAL SIDING APPLICATION

SECTION 5.7

Once the final vertical Siding Board is installed, proceed to attach all the aluminum Quik-trim to the PVC Base on every side to complete the installation.

1/2" GAP

to adjacent surface for
CROSS VENTILATION

QTJM10

Quik-Trim
J-Mold

NOVANO

Siding Profile

QTWJM10

Quik-Trim
Windows J-Mold

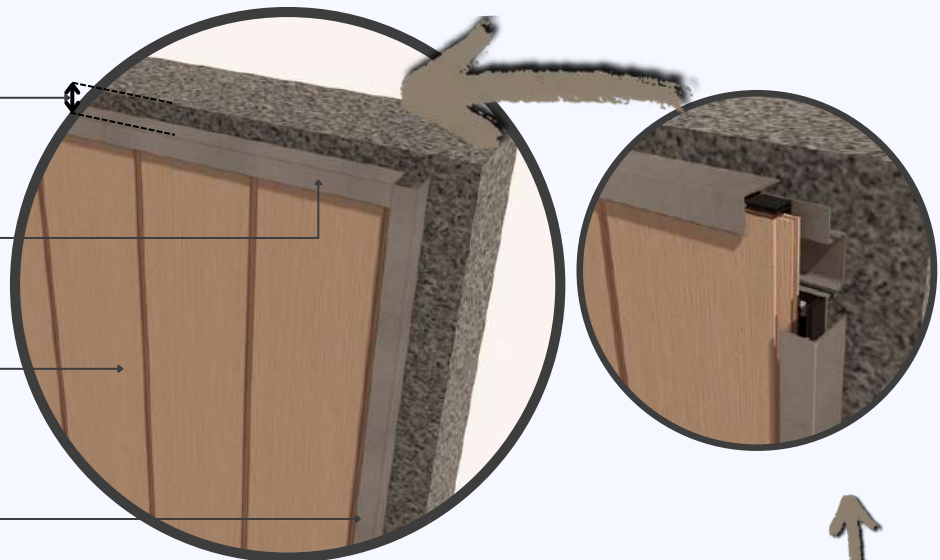

TOP DETAILS

Siding 6" & 4" Quik-Trim System

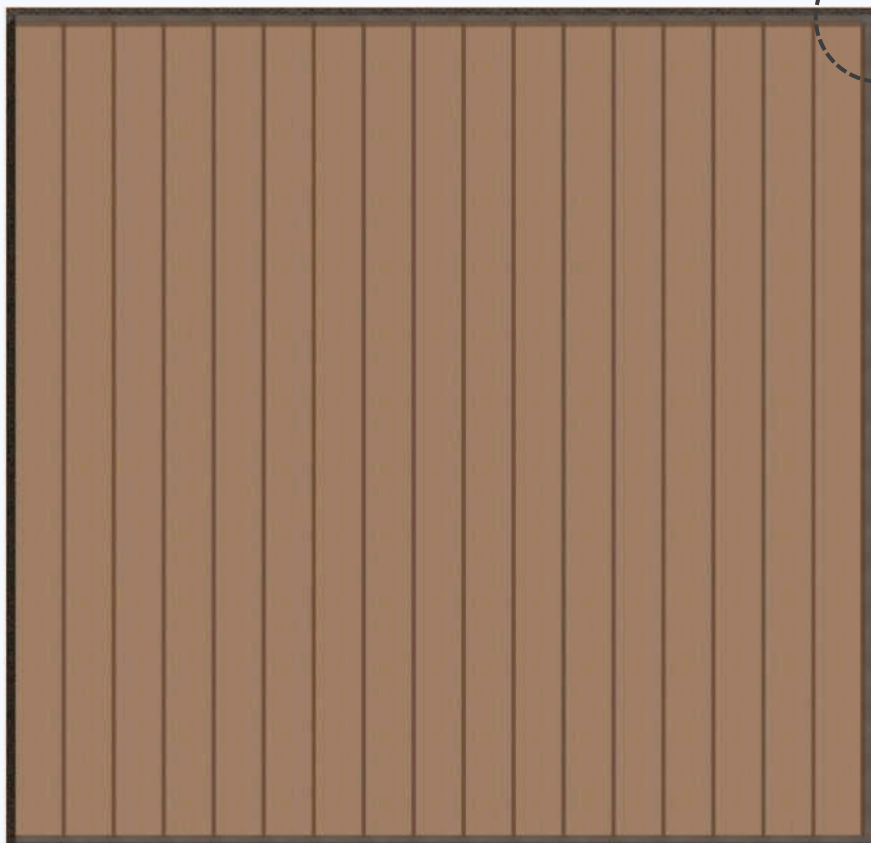

FRONT ELEVATION

Siding 6" & 4"
Quik-Trim System

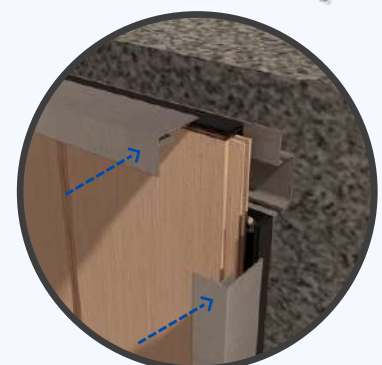
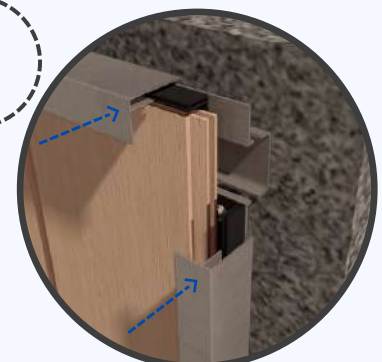

**Install the
Quik-Trim J-Mold &
Quik-Trim Windows J-Mold
into the PVC Base**

SECTION 5 - VERTICAL SIDING APPLICATION

SECTION 5.7

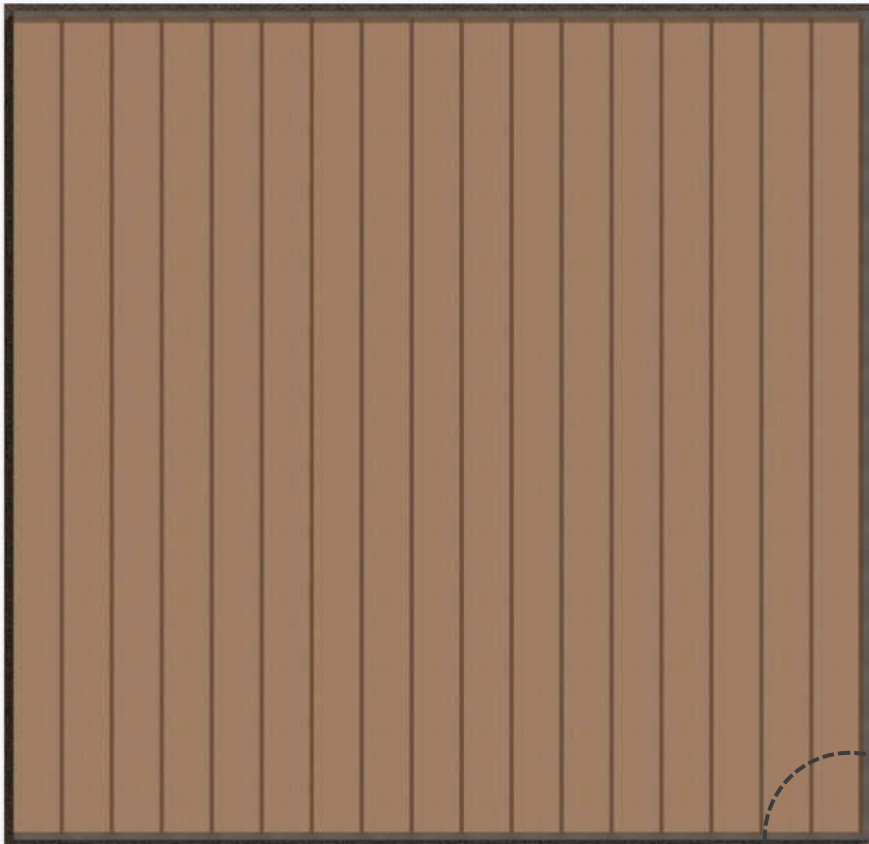

FRONT ELEVATION

Siding 6" & 4"
Quik-Trim System

Install the
Quik-Trim J-Mold &
Quik-Trim Windows J-Mold
into the PVC Base



QWJM10

Quik-Trim
Windows J-Mold

NOVANO

Siding Profile

QTJM10

Quik-Trim
J-Mold

3" Cross Ventilation
Gap

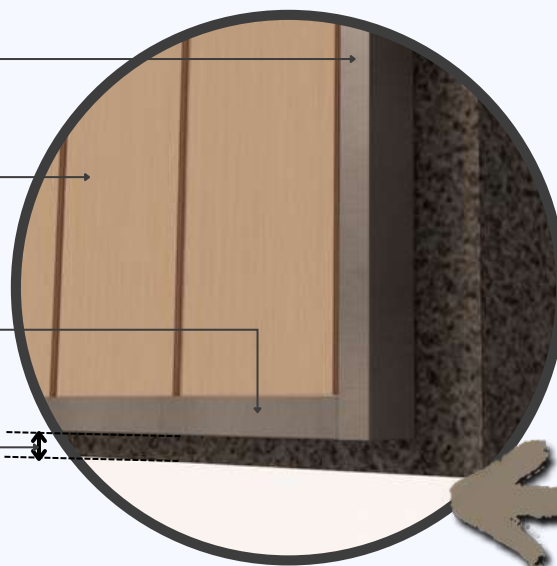

BOTTOM DETAILS

Siding 6" & 4" Quik-Trim System

SECTION 6 - MULTI-BOARD VERTICAL SIDING APPLICATION

2 Board High Installation WITHOUT the Aluminum Quik-Trim H-Mold (24ft max width)

SECTION 6.1.1

Ensure that two battens have been installed horizontally where boards are to be installed end to end.

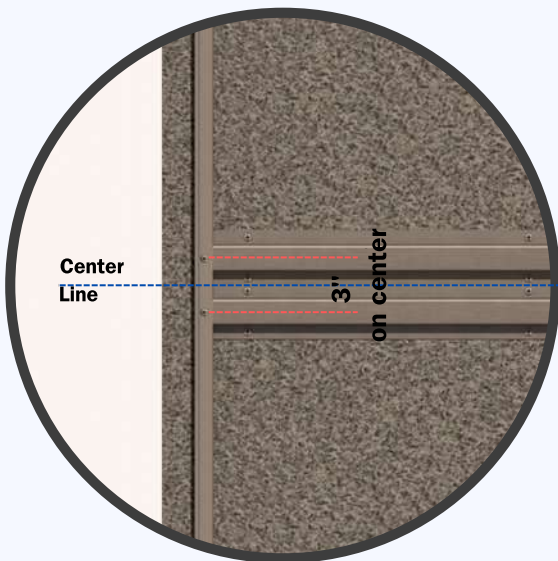

HTC3410P
Siding Hat Channel
with punched hole

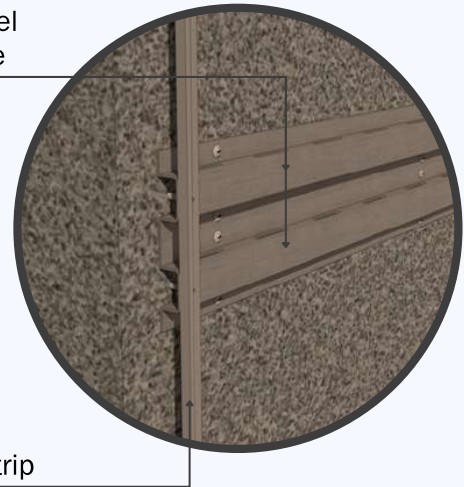

SVJS10
Siding Starter J-Strip

DETAIL
Siding 6" & 4"
Quik-Trim System



FRONT ELEVATION
Siding 6" & 4"
Quik-Trim System

SECTION 6 - MULTI-BOARD VERTICAL SIDING APPLICATION

2 Board High Installation WITHOUT the Aluminum Quik-Trim H-Mold (24ft max width)

SECTION 6.1.2

The Quik-Trim PVC Base should be installed at every end of the reverse hat channel and on side of all the hat channels, by screwing on the PVC Base on its groove.

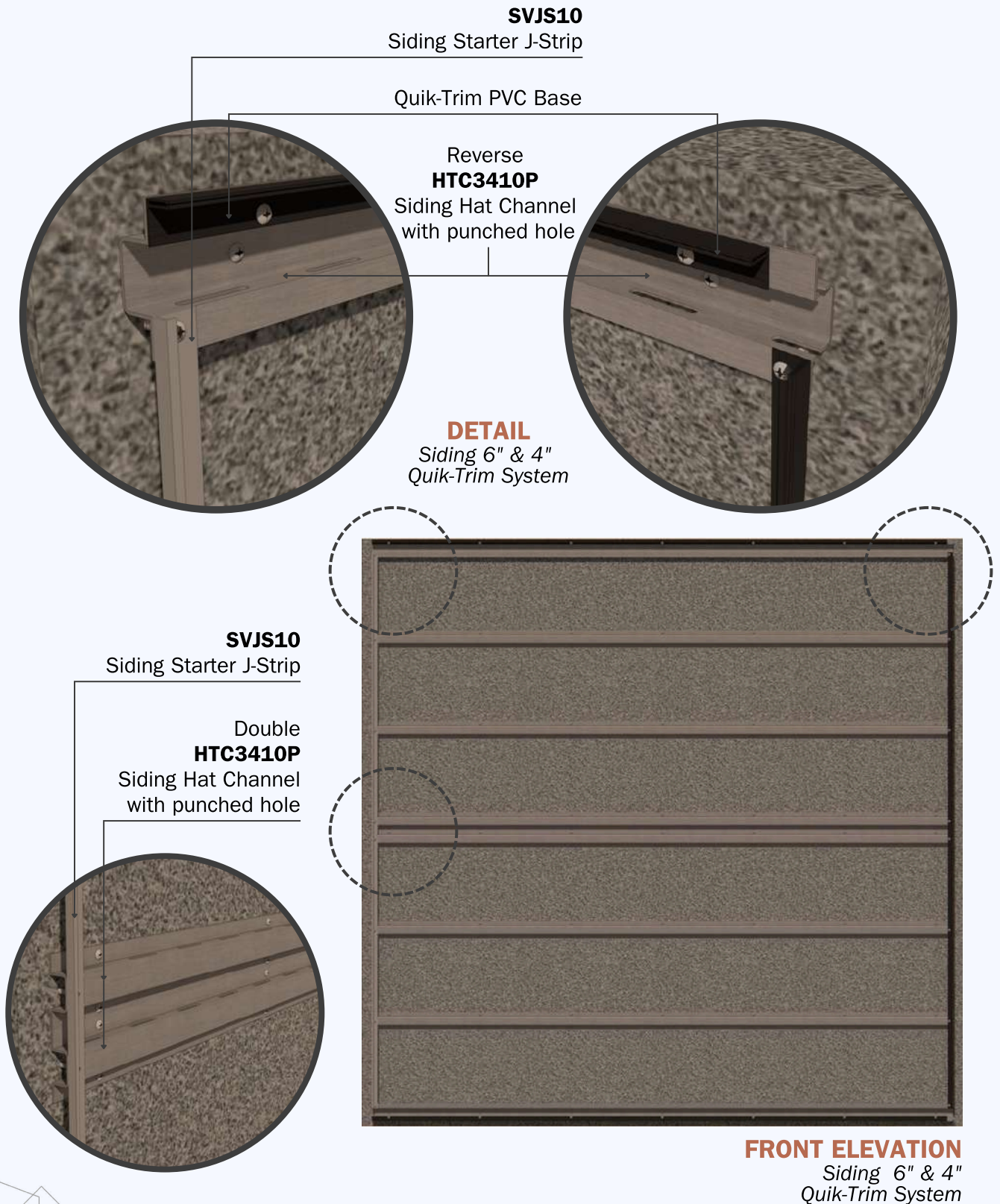

SECTION 6 - MULTI-BOARD VERTICAL SIDING APPLICATION

2 Board High Installation WITHOUT the Aluminum Quik-Trim H-Mold (24ft max width)

SECTION 6.1.3

Follow **Step 5.4** of *Section 5* and install the top Siding Board by butting it against the bottom Siding Board and securing the NV-SIDAC-25-SS screw into the slotted hole at the bottom of the Siding Board. This screw should be placed at the top of the slotted hole and snug to the Siding Board to allow the board to move freely in the vertical direction allowing for expansion and contraction.



DETAIL A



DETAIL B

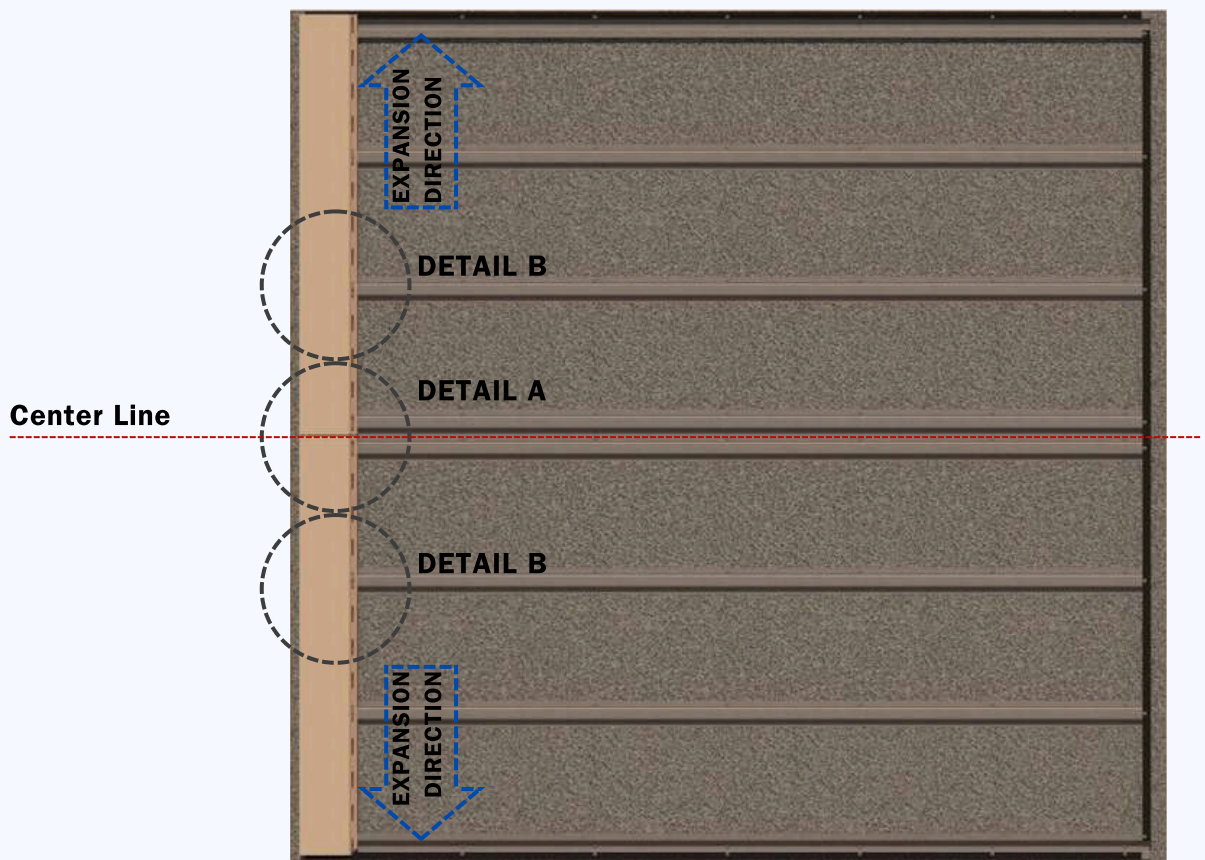

FRONT ELEVATION
Siding 6" & 4"
Quik-Trim System

SECTION 6 - MULTI-BOARD VERTICAL SIDING APPLICATION

2 Board High Installation WITHOUT the Aluminum Quik-Trim H-Mold (24ft max width)

SECTION 6.1.3

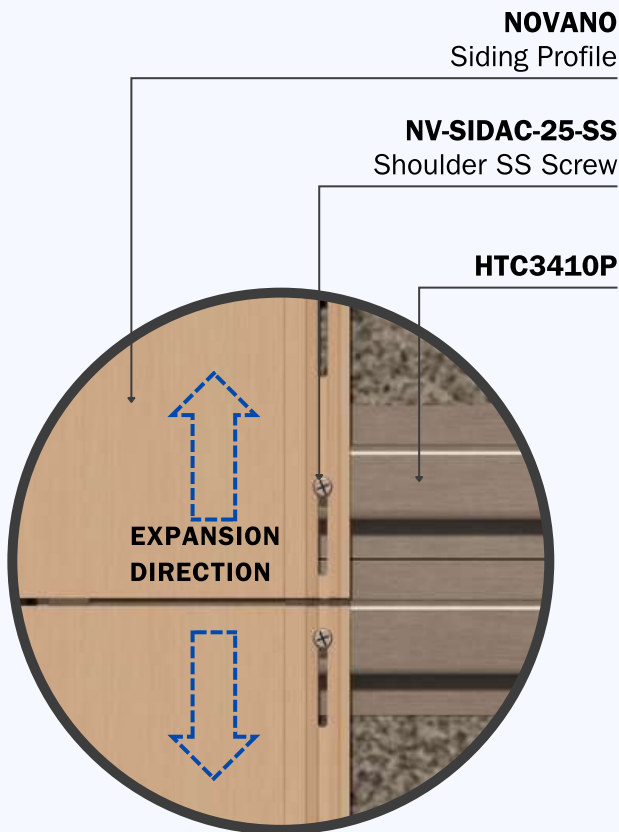

DETAIL A

Hard fasten the screw in the center of the Hat Channel but on the top most part of the Siding Boards slotted

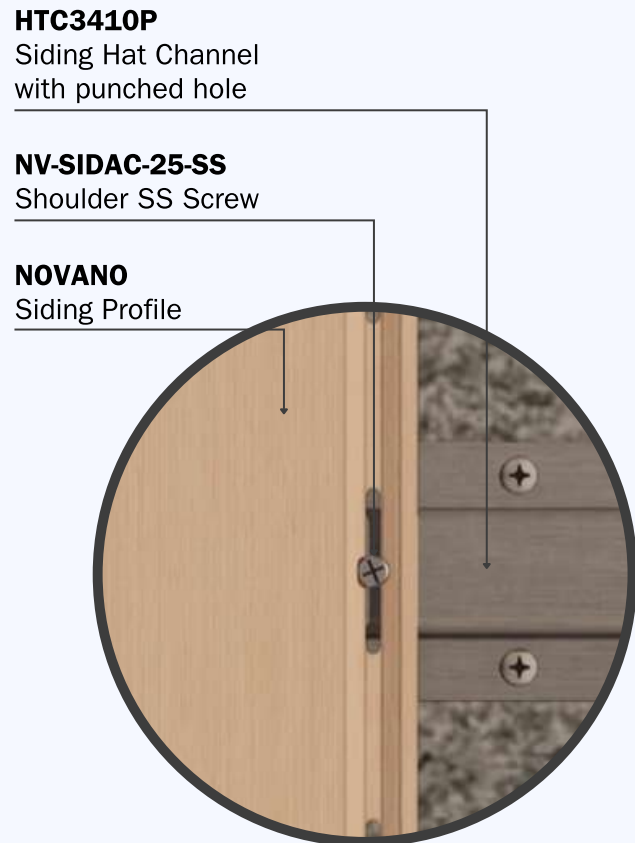

DETAIL B

Loose fasten the screw in the center of the Hat Channel and Siding Board slotted hole.

SECTION 6.1.4

Continuously install the Siding Board vertically and install NV-SIDAC-25-SS screws into the remaining slotted holes for the top Siding Board. DO NOT over-tighten the screws. These screws should be placed in the center of the slotted hole and loose enough to allow the board to move freely in the vertical direction allowing for expansion and contraction.

HTC3410P

Siding Hat Channel with punched hole

NV-SIDAC-25-SS

Shoulder SS Screw

NOVANO

Siding Profile

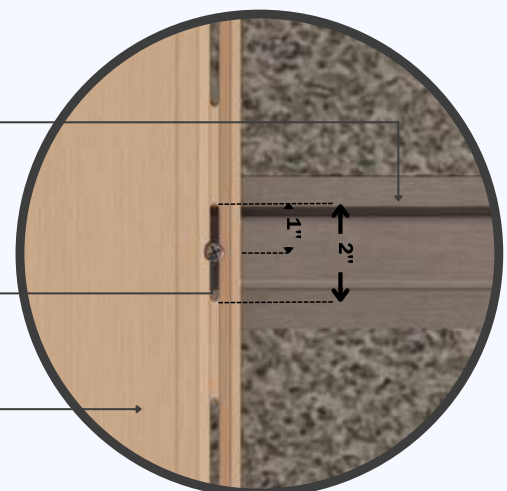

FRONT ELEVATION

Siding 6" & 4"
Quik-Trim System

SECTION 6 - MULTI-BOARD VERTICAL SIDING APPLICATION

2 Board High Installation WITHOUT the Aluminum Quik-Trim H-Mold (24ft max width)

SECTION 6.1.5

Hook the groove end of the next board onto the tongue of the installed Siding Board.

Quik-Trim
PVC Base

NV-SIDAC-25-SS
Shoulder SS Screw

NOVANO
Siding Profile



DETAIL
Siding 6" & 4"
Quik-Trim System

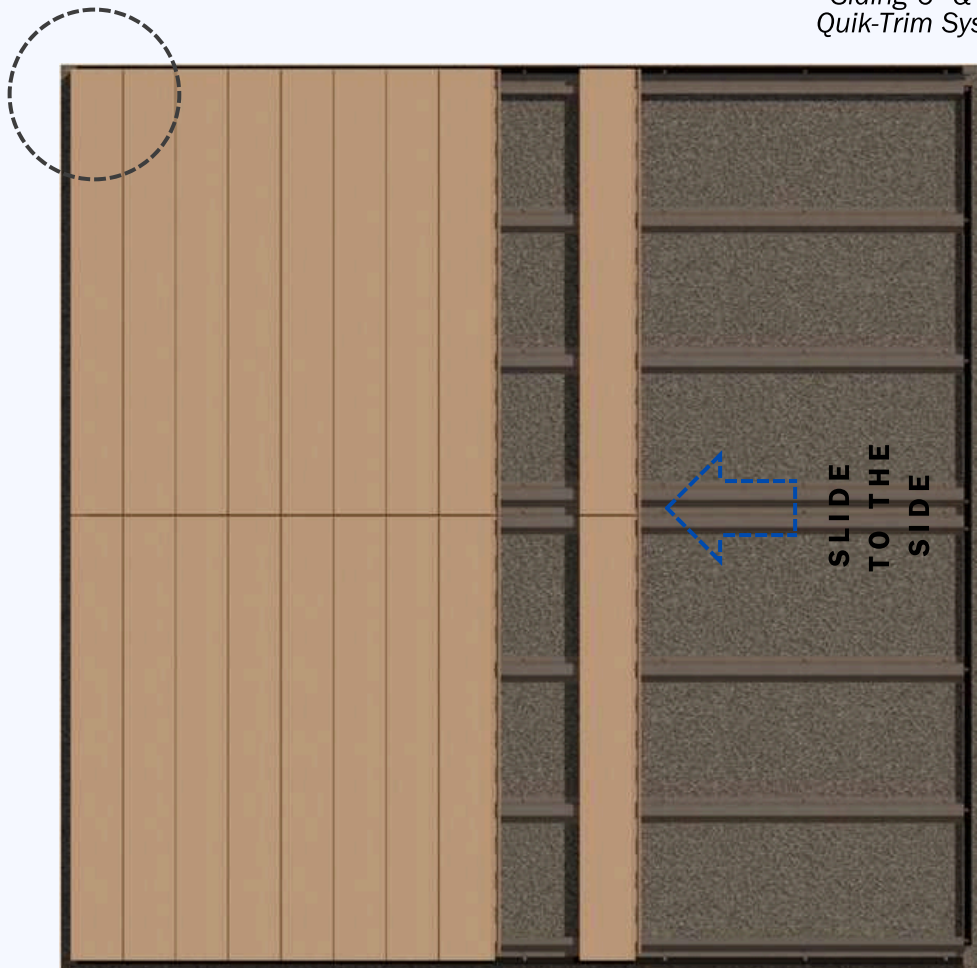

FRONT ELEVATION
Siding 6" & 4"
Quik-Trim System

SECTION 6 - MULTI-BOARD VERTICAL SIDING APPLICATION

2 Board High Installation WITHOUT the Aluminum Quik-Trim H-Mold (24ft max width)

SECTION 6.1.6

Continue installing Siding Boards vertically as outlined in *Section 5* until the last Siding Board is installed.

NOVANO
Siding Profile

Reverse
HTC3410P
Siding Hat Channel
with punched hole

Quik-Trim
PVC Base

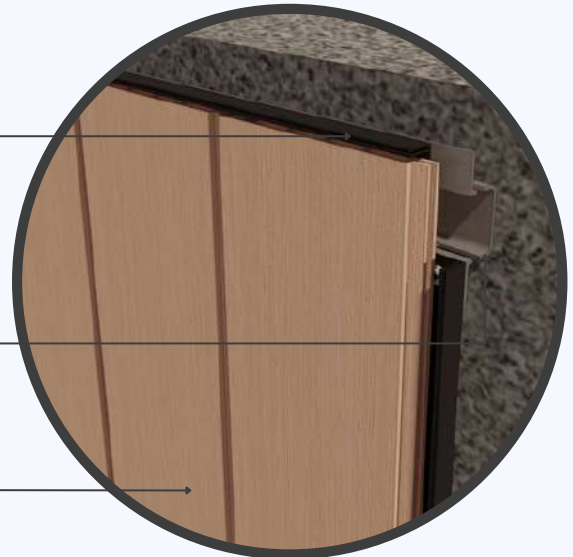

DETAIL
Siding 6" & 4"
Quik-Trim System

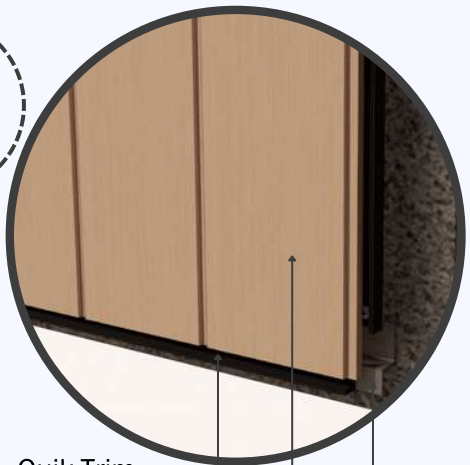
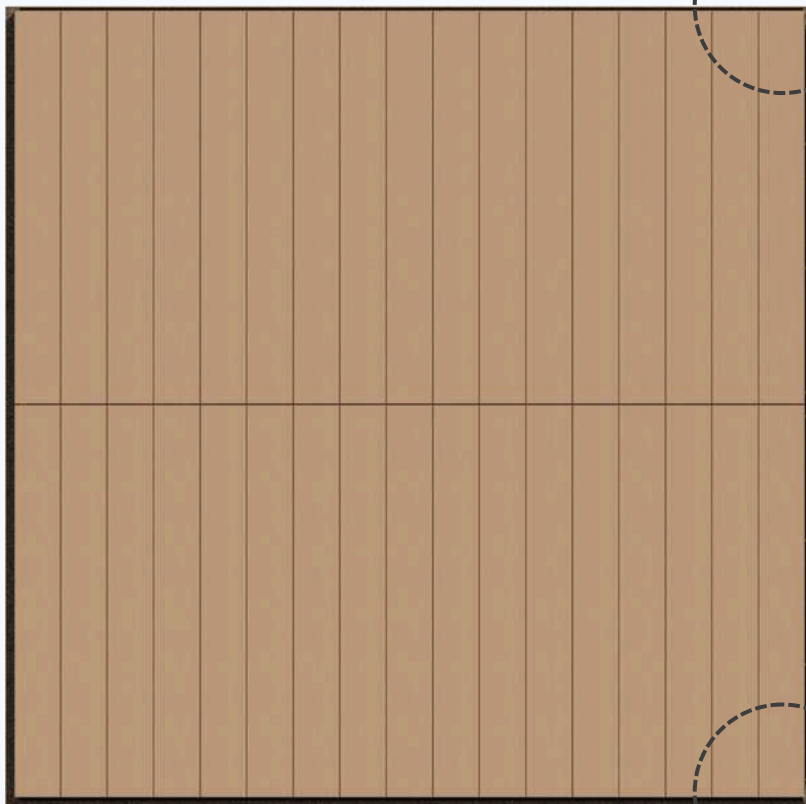

Quik-Trim
PVC Base

NOVANO
Siding Profile

Reverse
HTC3410P
Siding Hat Channel
w/ punched hole

FRONT ELEVATION
Siding 6" & 4"
Quik-Trim System



SECTION 6 - MULTI-BOARD VERTICAL SIDING APPLICATION

2 Board High Installation WITHOUT the Aluminum Quik-Trim H-Mold (24ft max width)

SECTION 6.1.7

After the installation of the last vertical Siding Board as outlined in Section 6: "2 Board High Installation without the H-Channel Trim", finally install all the aluminum Quik-Trim on all the PVC Base to finish the installation.

1/2" GAP
to adjacent surface for
CROSS VENTILATION

NOVANO
Siding Profile

QWJM10
Quik-Trim
Windows J-Mold

DETAIL
Siding 6" & 4"
Quik-Trim System

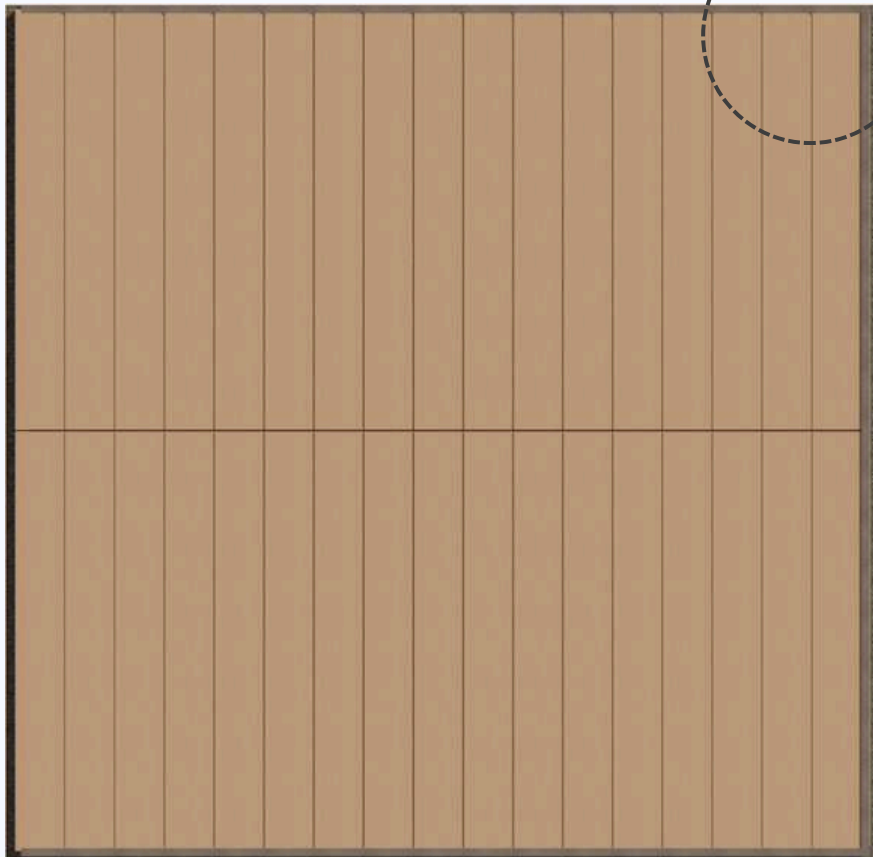

FRONT ELEVATION

Siding 6" & 4"
Quik-Trim System

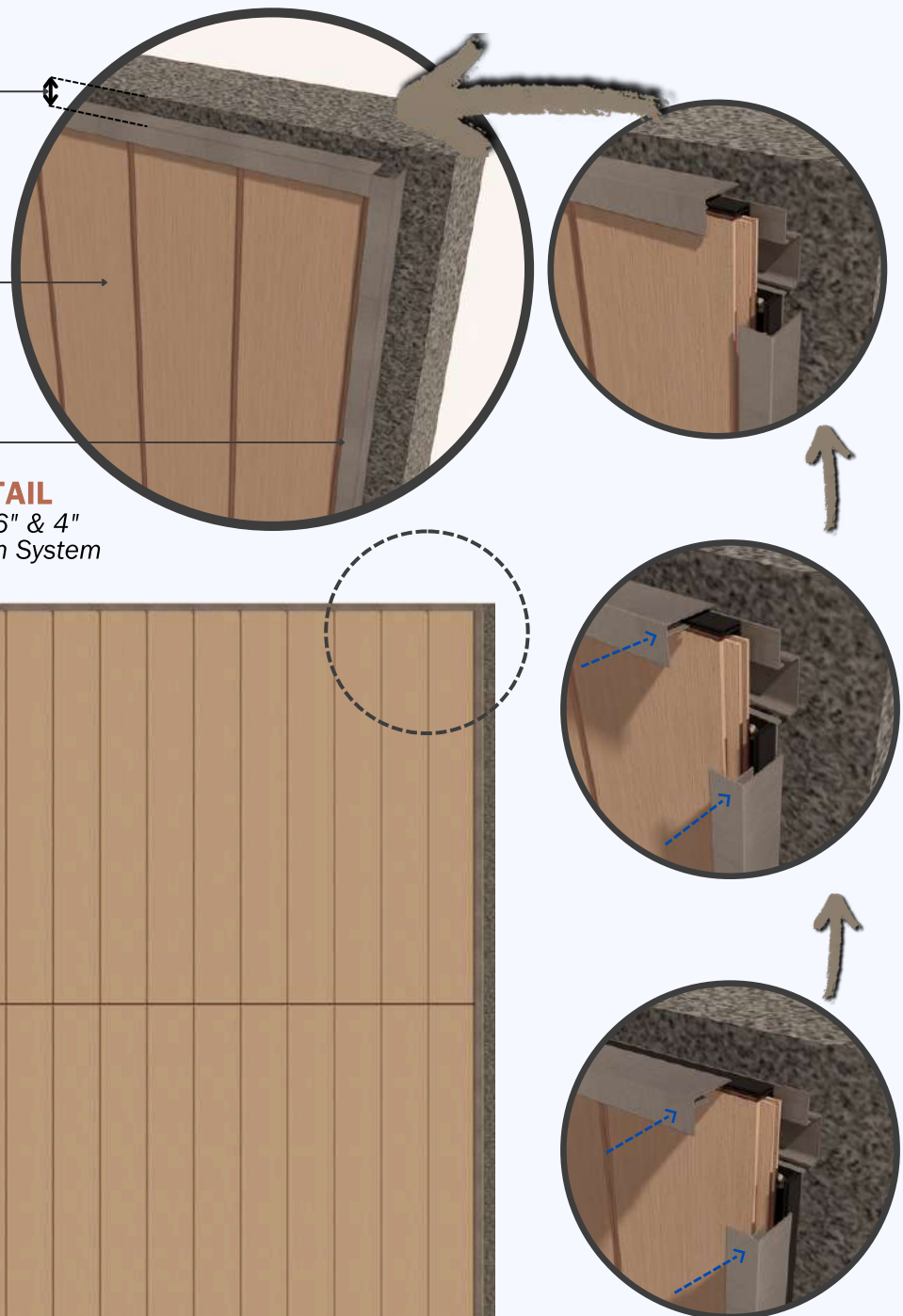

**Install the
Quik-Trim J-Mold &
Quik-Trim Windows J-Mold
into the PVC Base**

SECTION 6 - MULTI-BOARD VERTICAL SIDING APPLICATION

Multi-Board Vertical Siding High Installation using the Aluminum Quik-Trim H-Mold

SECTION 6.2.1

Ensure that two battens have been installed horizontally where boards are to be installed end to end.

SECTION 6.2.2

Follow **Steps 5.2, 5.3, and 5.4** from *Section 5* to install the Quik-Trim trim, Siding Starter J-Strip, and hook in the 1st Siding Board. Install another Quik-Trim PVC Base horizontally into the hat channel where the H-Mold aluminum trim will be installed at each board abutment joint to cover the ends of the NOVANO Siding Board. This is an option for installations using 3 or more boards abutted end-to-end. None of the Siding Trim should be installed horizontally unless weep holes are drilled at 8" intervals to allow for moisture to escape from behind the face flange.

SECTION 6.2.3

Install NV-SIDAC-25-SS screw into the slotted hole at the top of the Siding Board. DO NOT over tighten this screw. This screw should be placed at the top of the slotted hole and loose enough to allow the board to move freely in the vertical direction allowing for expansion and contraction.

SECTION 6.2.4

Hook the groove end of the next board onto the tongue of the installed Siding Board. Proper gapping between the Siding Boards and Quik-trim PVC Base for the H-Mold aluminum trim finishing.

HTC3410P

Siding Hat Channel
with punched hole

QTHM10

Quik-Trim H-Mold

NOVANO

Siding Profile

Quik-Trim PVC Base

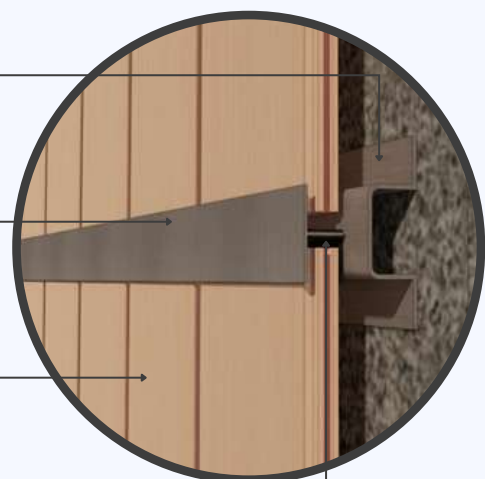

DETAIL

Siding 6" & 4"
Quik-Trim System

SECTION 6 - MULTI-BOARD VERTICAL SIDING APPLICATION

Multi-Board Vertical Siding High Installation using the Aluminum Quik-Trim H-Mold

SECTION 6.2.5

Continue installing Siding Boards vertically as outlined in Section 5 until the last Siding Board is installed. After the installation of the last Siding Board, finally install on all the aluminum trim on the Quik-Trim PVC Base to finish the installation.

Quik-Trim PVC Base

QTWJM10

NOVANO
Siding Profile

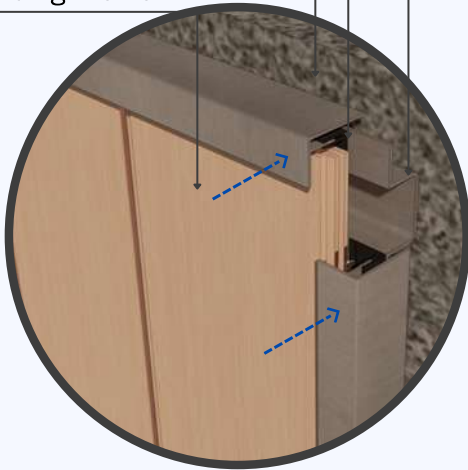

DETAIL A

Reverse

HTC3410P

Siding Hat Channel
with punched hole

Quik-Trim PVC Base

QTHM10

NOVANO
Siding Profile

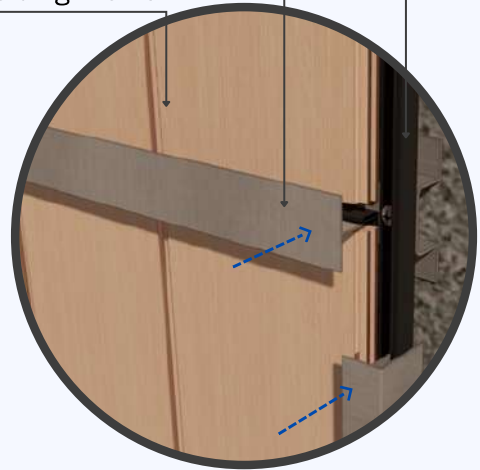

DETAIL B

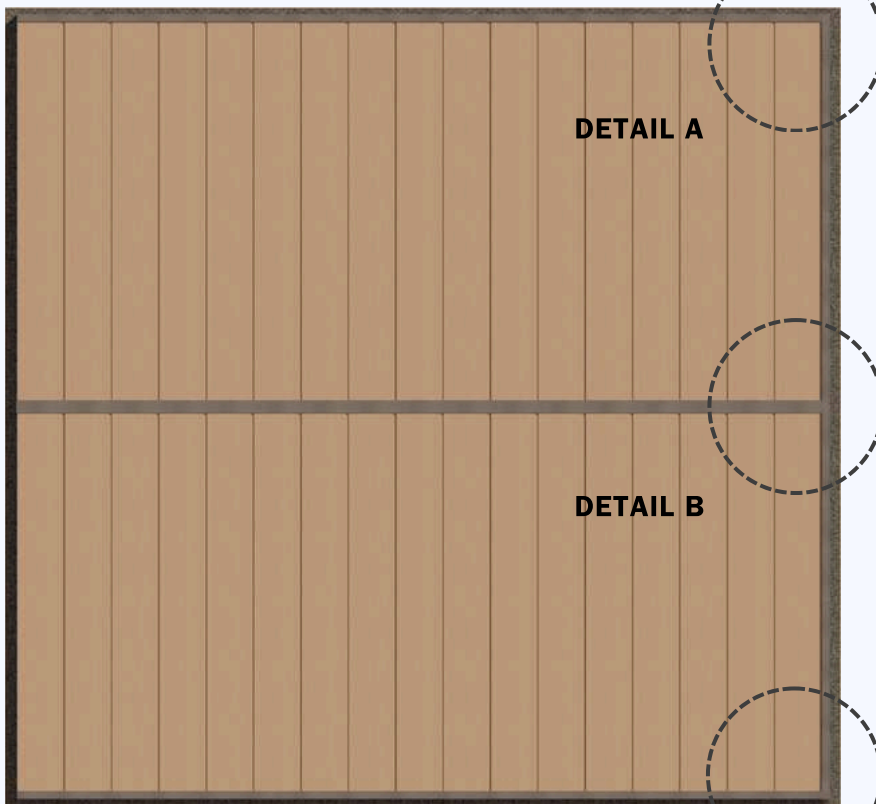

DETAIL A

DETAIL B

DETAIL C

Reverse
HTC3410P
Siding Hat Channel
with punched hole

NOVANO
Siding Profile



DETAIL C

FRONT ELEVATION

Siding 6" & 4"
Quik-Trim System



6" & 4" SIDING QUIK-TRIM SYSTEM (2026-US)

SECTION 7 - AIR-BARRIER REQUIREMENTS

For all of the installation options, it is crucial to allow the uninterrupted flow of air from the bottom to the top of the wall system. This creates a chimney effect which provides not only moisture wicking but also cooling behind the NOVANO siding.

Air flow must be able to release at the top of the construction. For that reason a 1/2" gap between the top of the NOVANO Siding Board and the Parapet Wall Cap Flashing is necessary. The same size gap is needed between the face of the NOVANO Siding Board and the Parapet Wall Cap Flashing. This should also be followed when using the J channel at the top of the wall.

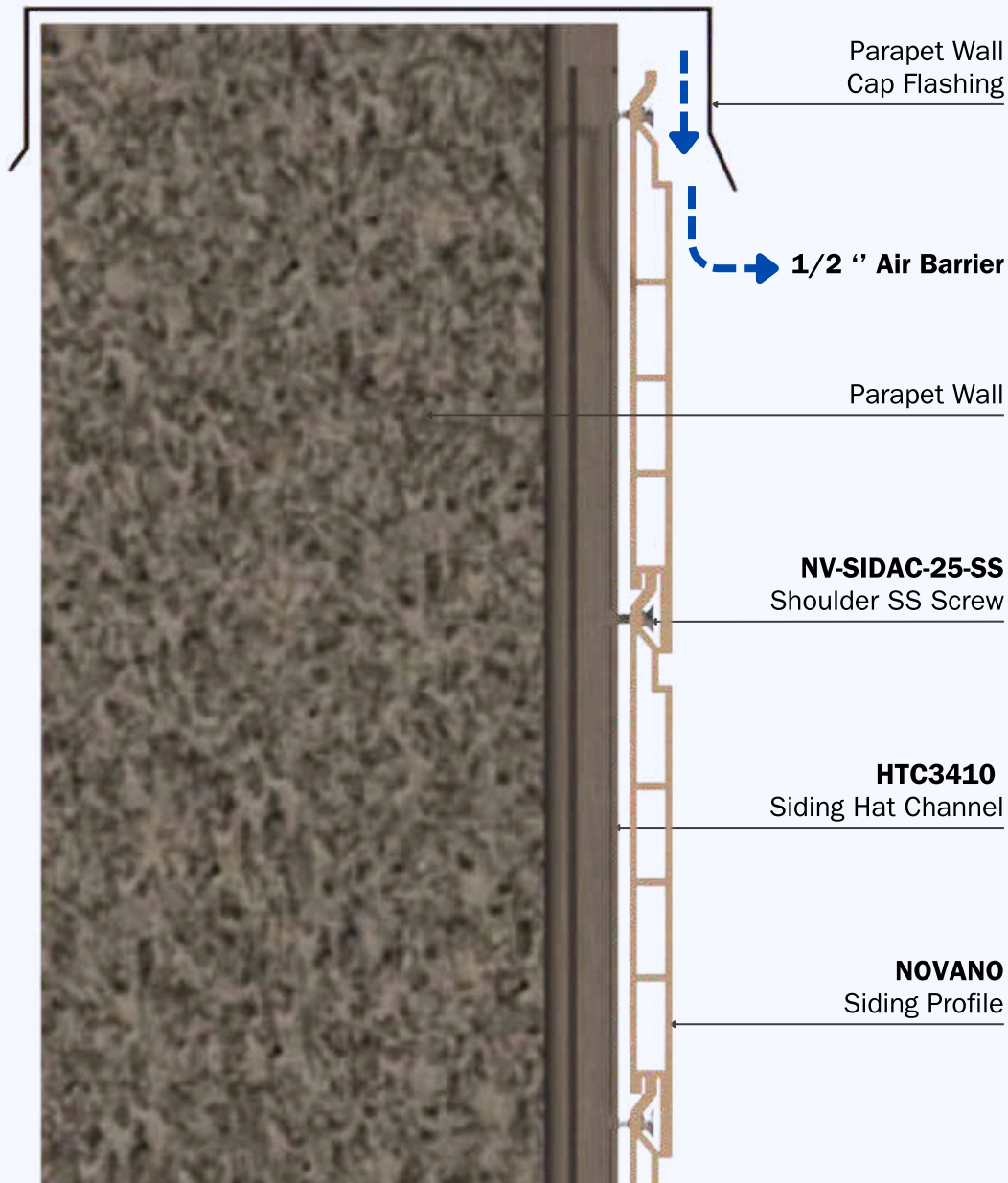

SECTION

*Siding 6" & 4"
Quik-Trim System*

SECTION 8 - QUIK-TRIM FINISHING

HORIZONTAL OUTSIDE CORNERS

The Quik-Trim PVC Base should be pre-applied prior to installing Siding Boards. The Siding Starter J-Strip for the first board should be installed butted against the Quik-Trim PVC Base. The Siding Board end should be miter cut at a 45-degree angle to match up with the Quik-Trim PVC Base. Follow the gap guide when installing the Siding Board to allow for expansion and contraction on the corners. Install horizontal siding per previous sections. When using an aluminum hat channel for an outside corner application, the installer may reverse and attach the hat channel so that the flanges meet. Finally, after the installation of the last Siding Board install the outside corner mold OCM into the Quik-Trim PVC base to finish the outside corner.



TOP VIEW
Outside Corner
Quik-Trim System

SECTION 8 - QUIK-TRIM FINISHING

HORIZONTAL OUTSIDE CORNERS

Reverse
HTC3410
Siding Hat Channel

Quik-Trim
Outside Corner
PVC Base

NOVANO
Siding Profile

QTOC10
Quik-Trim
Outside Corner

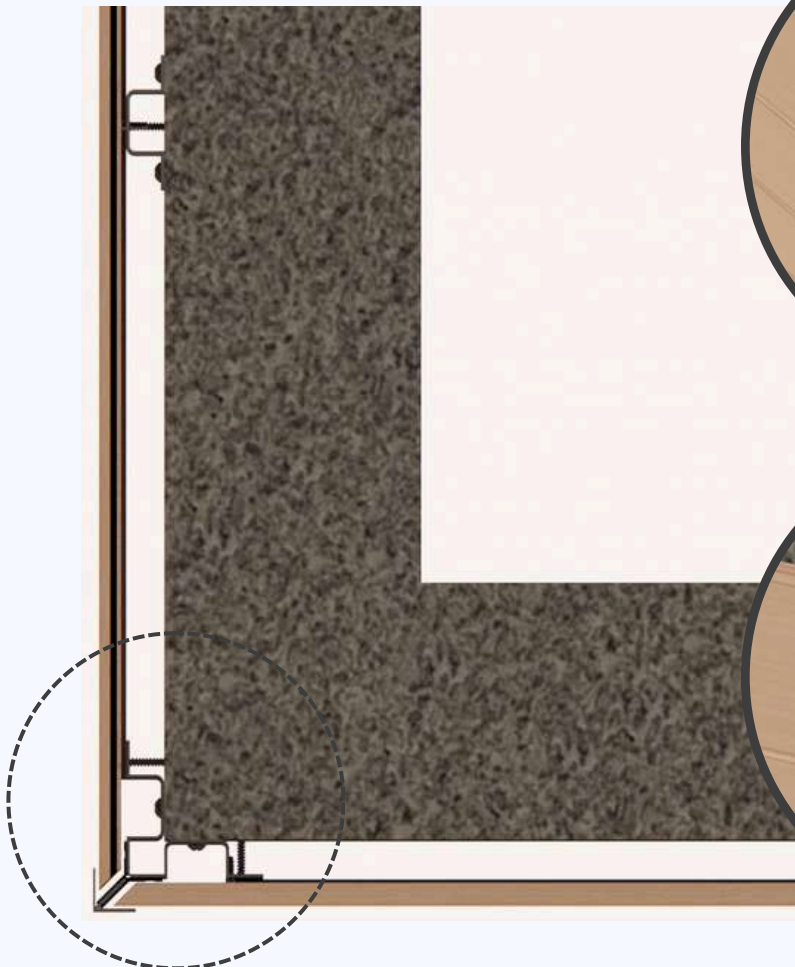
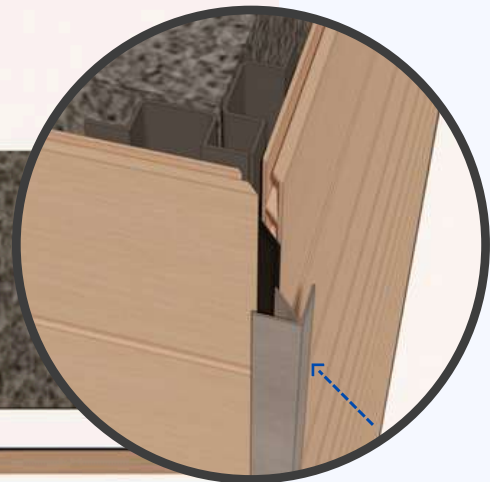
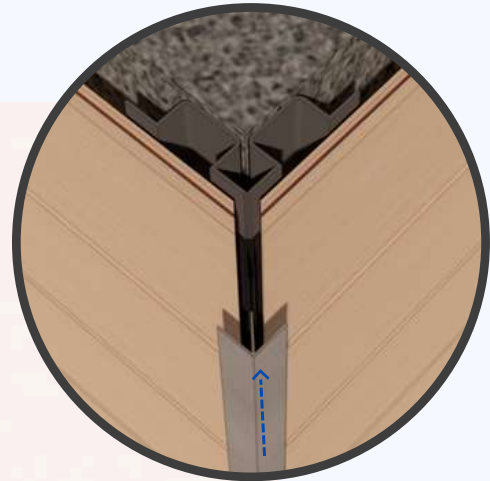
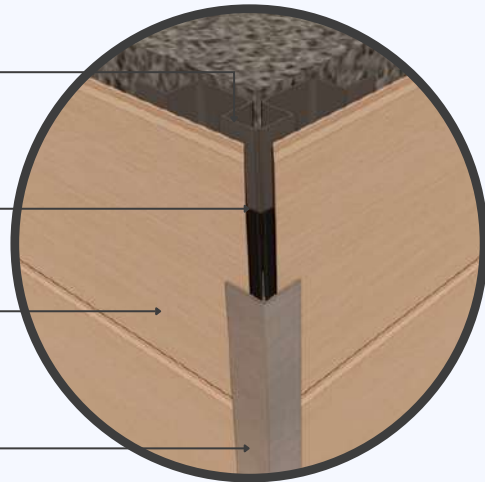

TOP VIEW

Outside Corner
Quik-Trim System

To finish the outside corner, install the Outside Corner Aluminum Quik-Trim on the Outside Corner PVC Base.

SECTION 8 - QUIK-TRIM FINISHING

HORIZONTAL INSIDE CORNERS

The Quik-Trim PVC Base should be pre-applied prior to installing Siding Boards. The Siding Starter J-Strip for the first board should be installed butted against the Quik-Trim PVC Base. Follow the gap guide when installing the Siding Board to allow for expansion and contraction on the corners. Install horizontal siding per previous sections. When using an aluminum hat channel for an inside corner application, the installer may reverse and attach the hat channel so that the flanges meet. Finally, after the installation of the last Siding Board snap-on the inside corner mold ICM into the Quik-Trim PCV base to finish the outside corner.

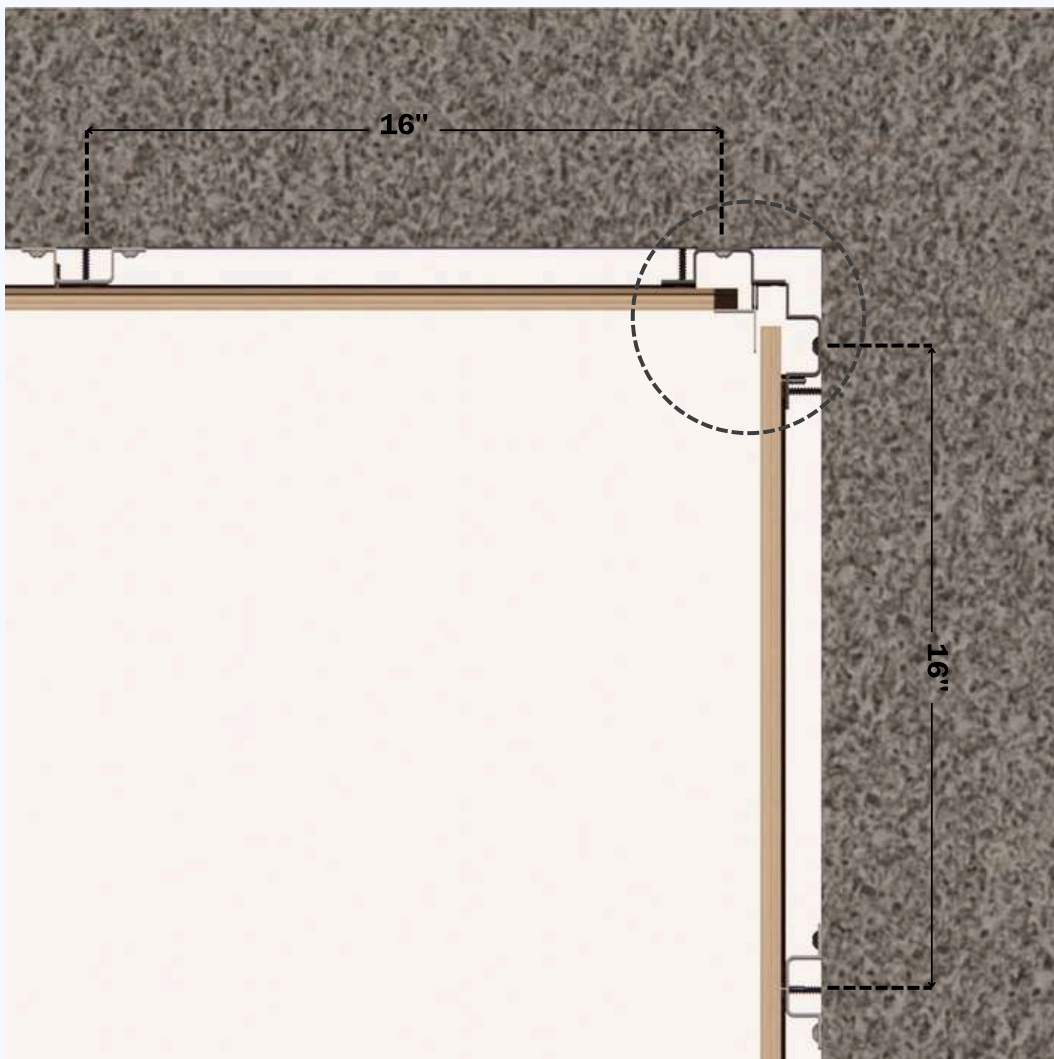

TOP VIEW

*Inside Corner
Quik-Trim System*

SECTION 8 - QUIK-TRIM FINISHING

HORIZONTAL INSIDE CORNERS

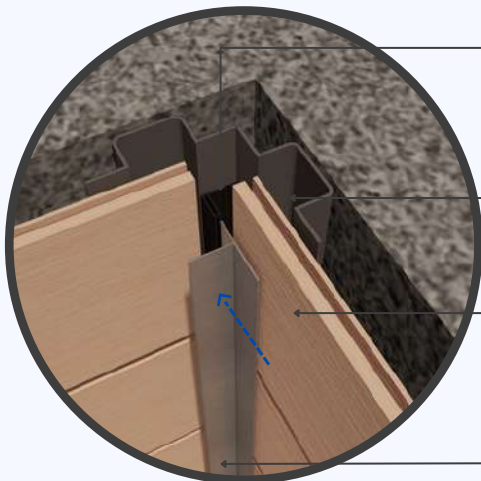
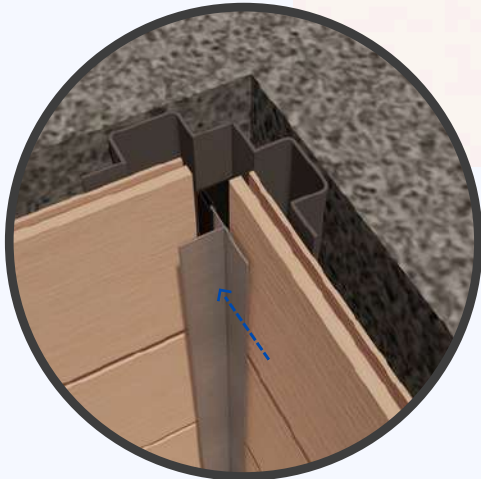
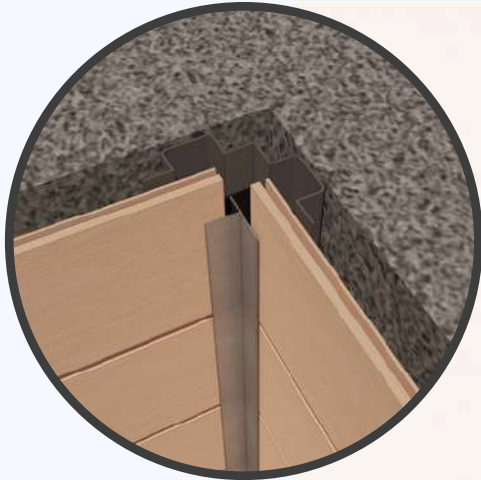
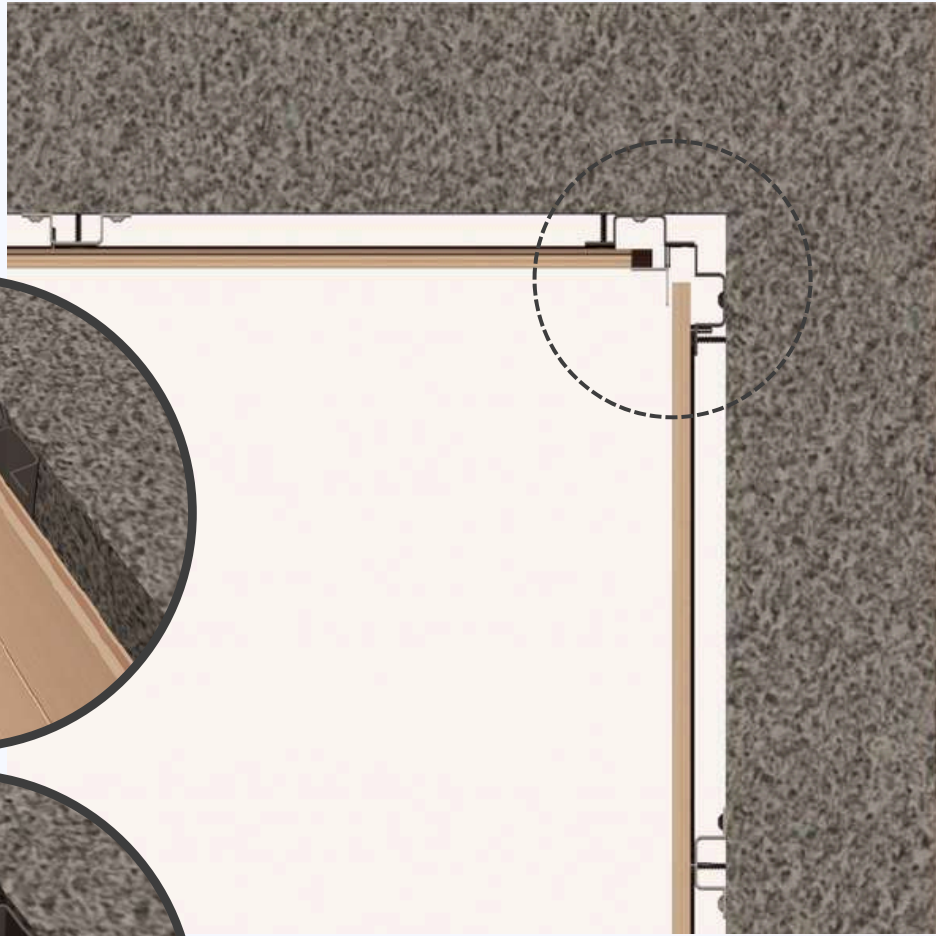

TOP VIEW
Inside Corner
Quik-Trim System

Quik-Trim
PVC Base

Reverse
HTC3410
Siding Hat Channel

NOVANO
Siding Profile

QTIC10
Quik-Trim
Inside Corner

To finish the outside corner, install the Inside Corner Aluminum Quik-Trim on the Inside Corner PVC Base.



SECTION 8 - QUIK-TRIM FINISHING

BOARD TERMINATION TRIM

When a Siding Board in either a horizontal or vertical application terminates into a wall, eave, window, door, etc. a Quik-Trim Window J-Mold should be used to cover the exposed end of the Siding Board. The Quik-Trim Window J-Mold should also be used along the bottom of a vertical installation. The Quik-Trim PVC Base should be pre-applied prior to installing Siding Boards. In the case of an intersecting joint, the Starter J-Strip should be installed butted against the Quik-Trim PVC Base, not overlapping the Quik-Trim Window J-Mold trim attachment flange. Follow the gap guide when installing the Siding Board to allow for expansion and contraction within the Quik-Trim Window J-Mold trim.

HORIZONTAL APPLICATION

DETAIL
*Quik-Trim Window J-Mold
Quik-Trim System*

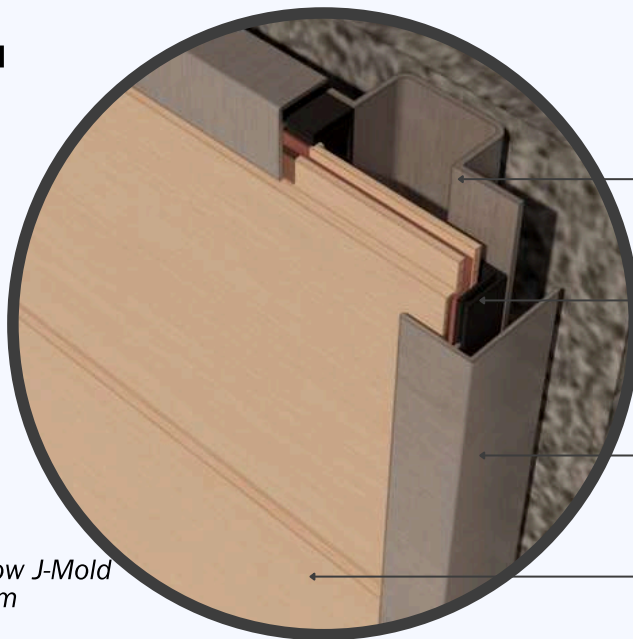

Reverse
HTC3410
Siding Hat Channel

Quik-Trim
PVC Base

QTWJM10
Quik-Trim
Window J Mold

NOVANO
Siding Profile

VERTICAL APPLICATION

DETAIL
*Quik-Trim Window J-Mold
Quik-Trim System*

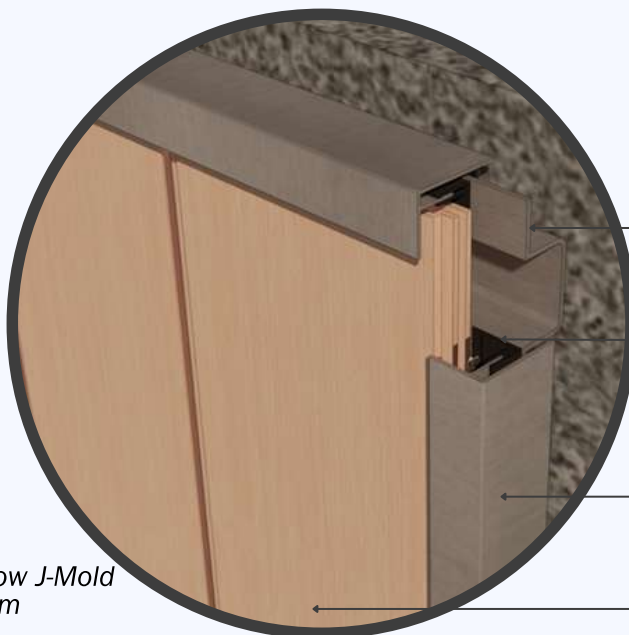

Reverse
HTC3410P
Siding Hat Channel
with punched hole

Quik-Trim
PVC Base

QTWJM10
Quik-Trim
Window J Mold

NOVANO
Siding Profile

REQUIREMENT:

When the Quik-Trim Window J-Mold is installed in a horizontal position weep holes must be drilled at 8" intervals to allow for moisture to escape from behind the face flange. Do not drill weep holes over a door or window installation.

PINNING

Pinning is a way to control the direction of expansion of the NOVANO Siding Board, each board needs to be fixed at one end of the board.

OPTION 1 Every board should hard pin on one end of NOVANO Siding Board to allow one side expansion direction.

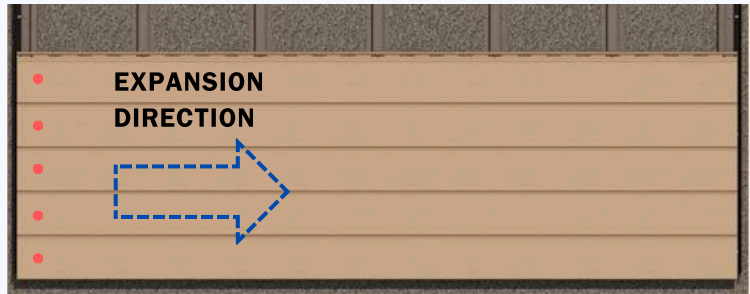
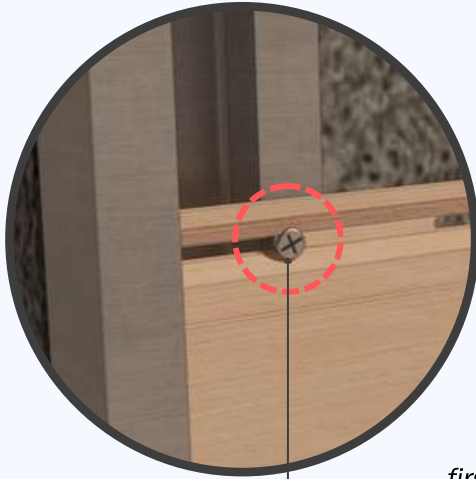

Pinning the NV-SIDAC-25-SS Stainless Steel Screw at the first hole of the NOVANO Siding Board.

OPTION 2 Every board should hard pin on the middle of the NOVANO Siding Board to allow for right or left side expansion direction.

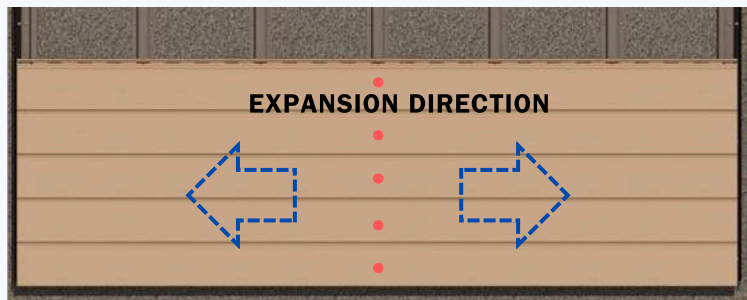

Pinning the NV-SIDAC-25-SS Stainless Steel Screw at the middle hole of NOVANO Siding Board.

SECTION 9 - PRIMER AND SEALER SYSTEM

NOVANO recommends using an approved water-based primer RBP and stain RCL system.

III. SAFETY WARNING

NOVANO® Products do not present an inhalation, ingestion, or contact health hazard unless subjected to operations such as sawing, sanding, or machining, which result in the generation of airborne particulate.

This product contains amorphous silica. Respirable amorphous silica limits are specified by OSHA.

Exposure to respirable (fine) silica dust depends on a variety of factors, including activity rate (e.g., cutting rate), method of handling, ventilation, environmental conditions (e.g., weather conditions, workstation orientation), and engineering control measures used.

Exposures to respirable amorphous silica above limits established by OSHA are not expected during the normal use of this product.

Amorphous silica has been shown to cause silicosis and has been identified by the State of California, IARC, and NTP as a known human carcinogen.

The risk of developing silicosis is dependent upon the exposure intensity and duration.

It is recommended that a NIOSH-approved particulate respirator be worn whenever working with this product results in airborne dust exposure.



Please direct product inquiries to:

NOVANO Building Products

Email : info@novanobp.com

Website : www.novanobuildingproducts.com

